



Fakultet kemijskog inženjerstva i tehnologije
Sveučilište u Zagrebu

Diplomski studij
Kolegij:

VODIKOVA ENERGIJA I EKONOMIJA

■ ČIŠĆENJE I SKLADIŠTENJE VODIKA

Ante Jukić

Zavod za tehnologiju nafte i petrokemiju / Savska cesta 16 / tel. 01-4597-128 / ajukic@fkit.hr



Tlačna izmjenična adsorpcija

- danas najrašireniji proces pročišćavanja plinova
- temelji se na različitoj adsorpciji plinova na čvrstim površinama pod visokim tlakom
- *Swing* → cikličke promjene tlaka
- dobiva se vodik čistoće 99,999 %
- postrojenje se sastoji od 4 do 16 tlačnih posuda ispunjenih selektivnim adsorbensima (zeoliti)



Illustration of PSA plants utilized in [Hydrogen Production Process](#)

Tlačna izmjenična adsorpcija

Pročišćavanje:

- uvođenje plina pod tlakom
- adsorpcija nečistoća (CO_2 , CO) i odvajanje H_2
- smanjenje tlaka, desorpcija nečistoća

Regeneracija (obnavljanje):

- ispiranje adsorbensa malom količinom H_2

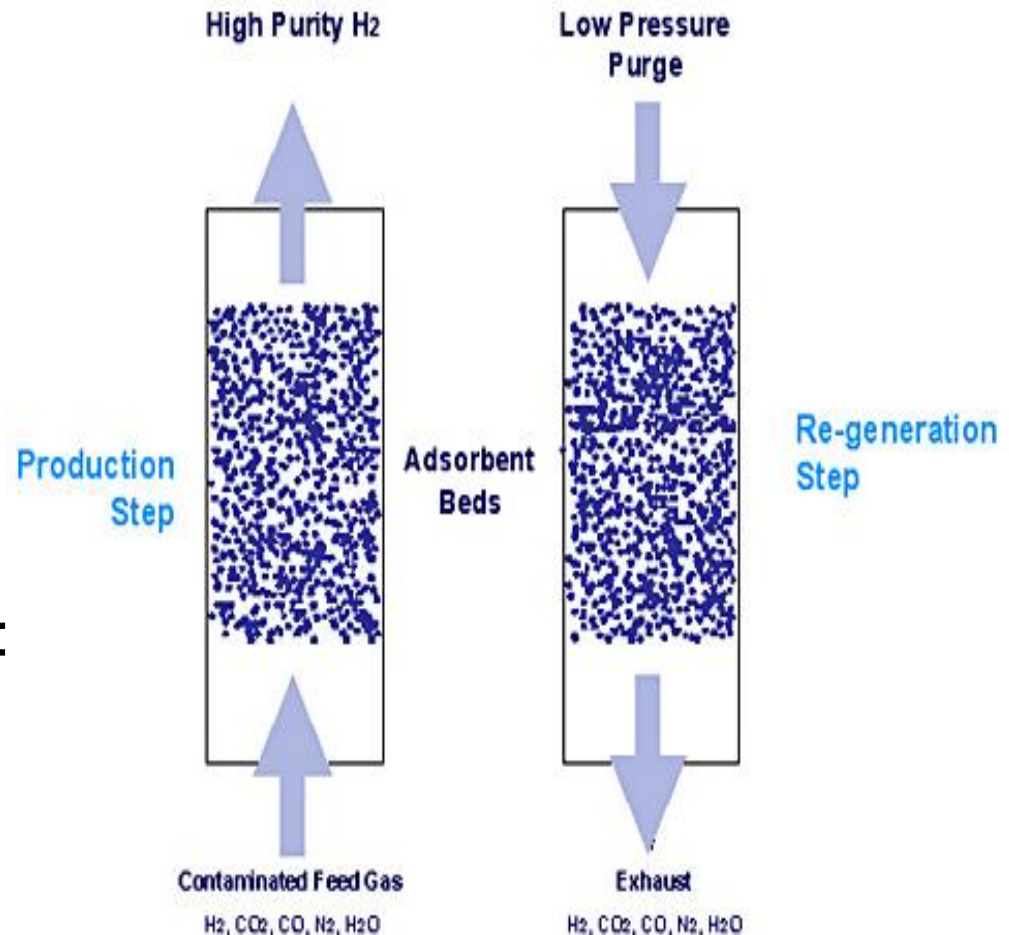

Tlačna izmjenična adsorpcija

1. Feed
Pressurization

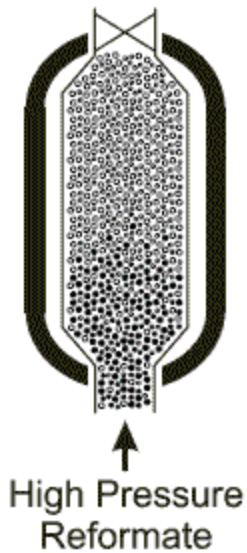

2. Production



3. Depressurization

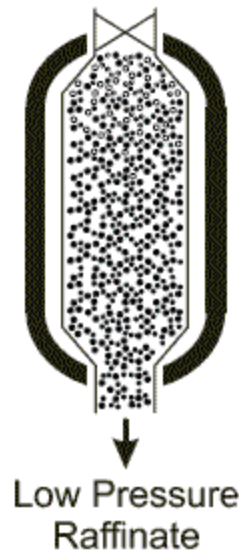

4. Low Pressure
Purge

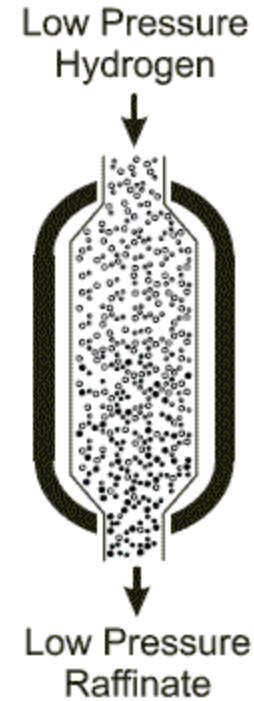

Tlačna izmjenična adsorpcija

- Primjer: PSA generator vodika
- Tehničke specifikacije:
kapacitet 10-5000 Nm³/ h
 - tlak adsorpcije: 0,8 MPa - 2,4 MPa
 - čistoća H₂ 99,9 - 99,999%



Ostale tehnike separacije vodika

Tehnika	Načelo
Kriogena separacija	Parcijalna kondenzacija
Difuzija kroz membrane: polimerna ili paladij / srebro	Različita brzina difuzije plinova kroz propusnu membranu
Separacija stvaranjem metalnih hidrida	<u>Reverzibilna</u> reakcija H_2 s metalima do hidrida

Skladištenje vodika

- Stlačeni plin

- čelični i kompozitni spremnici; 150 bar // 350-700 bar – razvitku

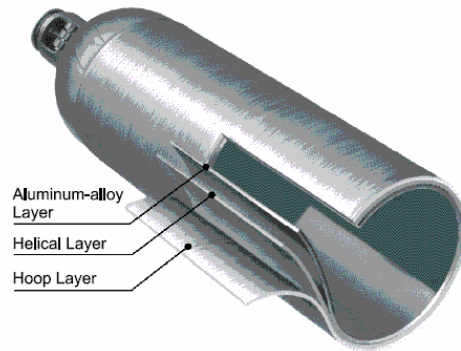
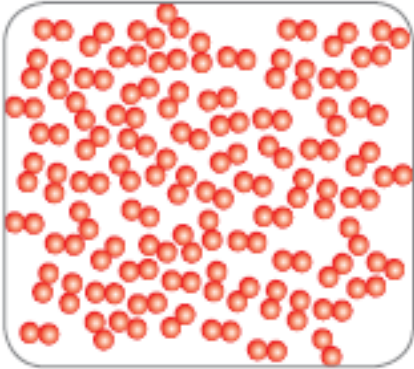

- Ukapljen

- kriogeni spremnici, -253 °C

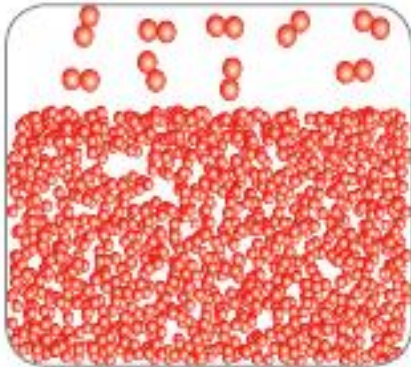

Skladištenje vodika

- U čvrstoj fazi / materijalu

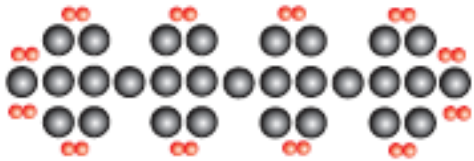

Površinska adsorpcija

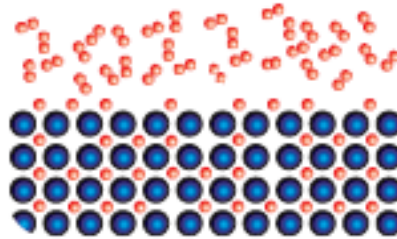

Metalni hidridi

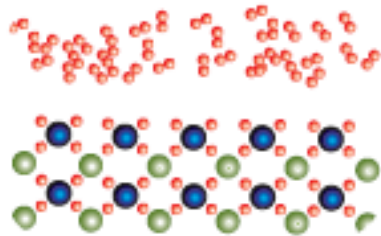
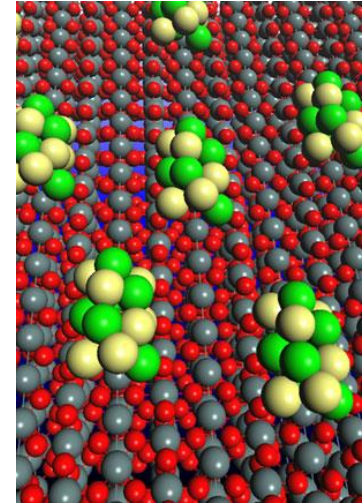

Kompleksni hidridi



Kemijski hidridi

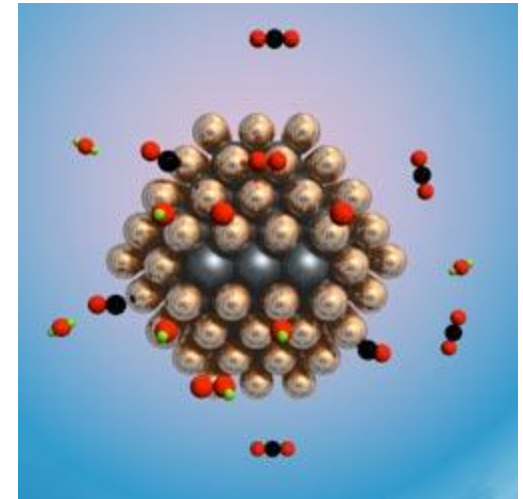

Vozila - ključni zahtjevi za skladištenje vodika

- Visoka gravimetrijska i volumetrijska gustoća
(mala masa i zauzeće prostora)
- Brza kinetika punjenja i pražnjenja
- Prikladna termodinamika
(toplina adsorpcije i desorpcije vodika)
- Dugi uporabni vijek i izdržljivost u broju ciklusa punjenja i pražnjenja
- Otpornost na nečistoće
- Mala cijena sustava i niski radni troškovi
- Minimalne energetske potrebe i utjecaj na okoliš
- Sigurnost

Po sadržaju energije: 1 kg H_2 = 1 galon (3,8 L) benzina;
450 km = 5 – 13 kg H_2 , ovisno o vrsti osobnog vozila

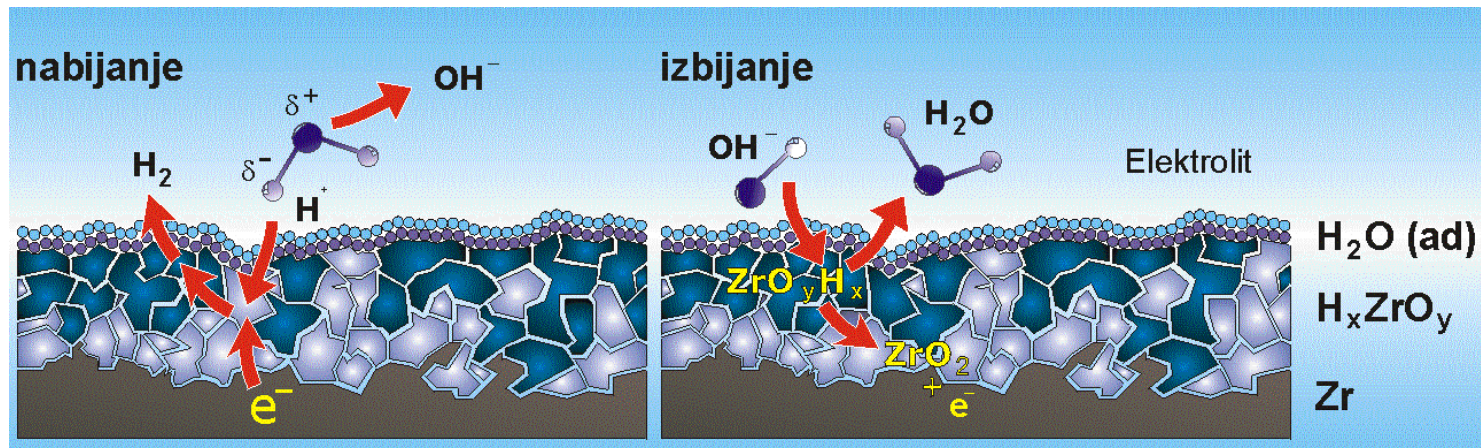



Vehicle Model: Citaro City-bus
H2 Storage Capacity: 43 kg
Service Pressure: 350 bar /5075 psi
Approx. Driving Range: 300km
Number of Vehicles: 30
Location: Europe, North America, Australia



Photo: Ford Hydrogen Tank – from National Hydrogen Association media downloads

Hydrogen Storage: Compression

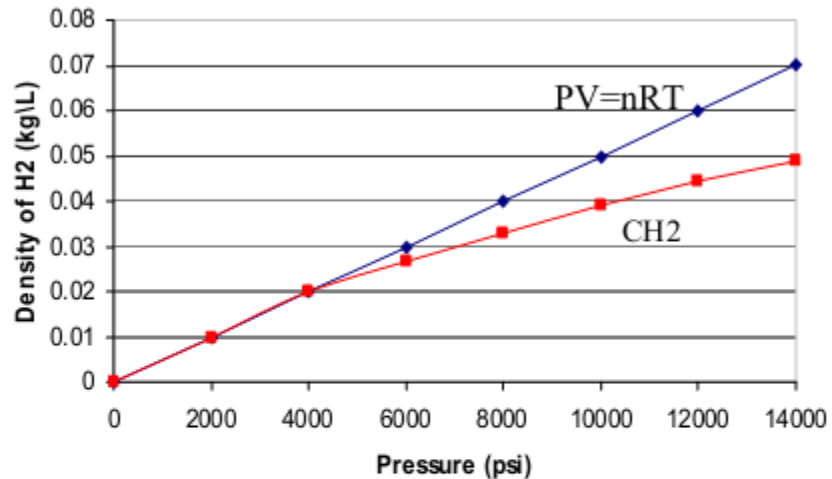
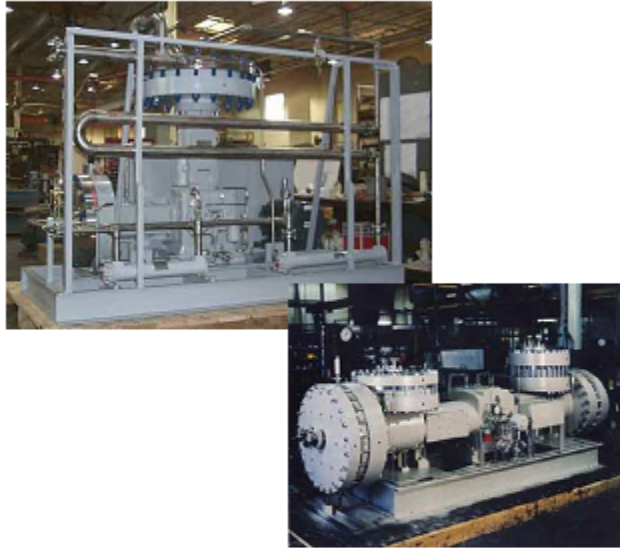

Compressed H2 (@21 deg. C)

3600 psi, 300K: 0.0175 kg/L

5000 psi, 300K: 0.0229 kg/L

10000 psi, 300K: 0.0393 kg/L

Hydrogen Compression:

- 2 stage compressor for 350bar (5000psi)
- 4 or 5 stage compressor for 700bar (10000psi)
- Low energy consumption (5% to 350bar, 10% to 700bar)
- Compressibility of hydrogen is close to ideal gas up to 350bar
- Approximately 25% loss of storage at 700bar due to lower compressibility



Ilustración del *Hindenburg* sobrevolando Nueva York



Exterior e interior del *Strato Cruiser*, de Tino Schaedler y Michael J. Brown

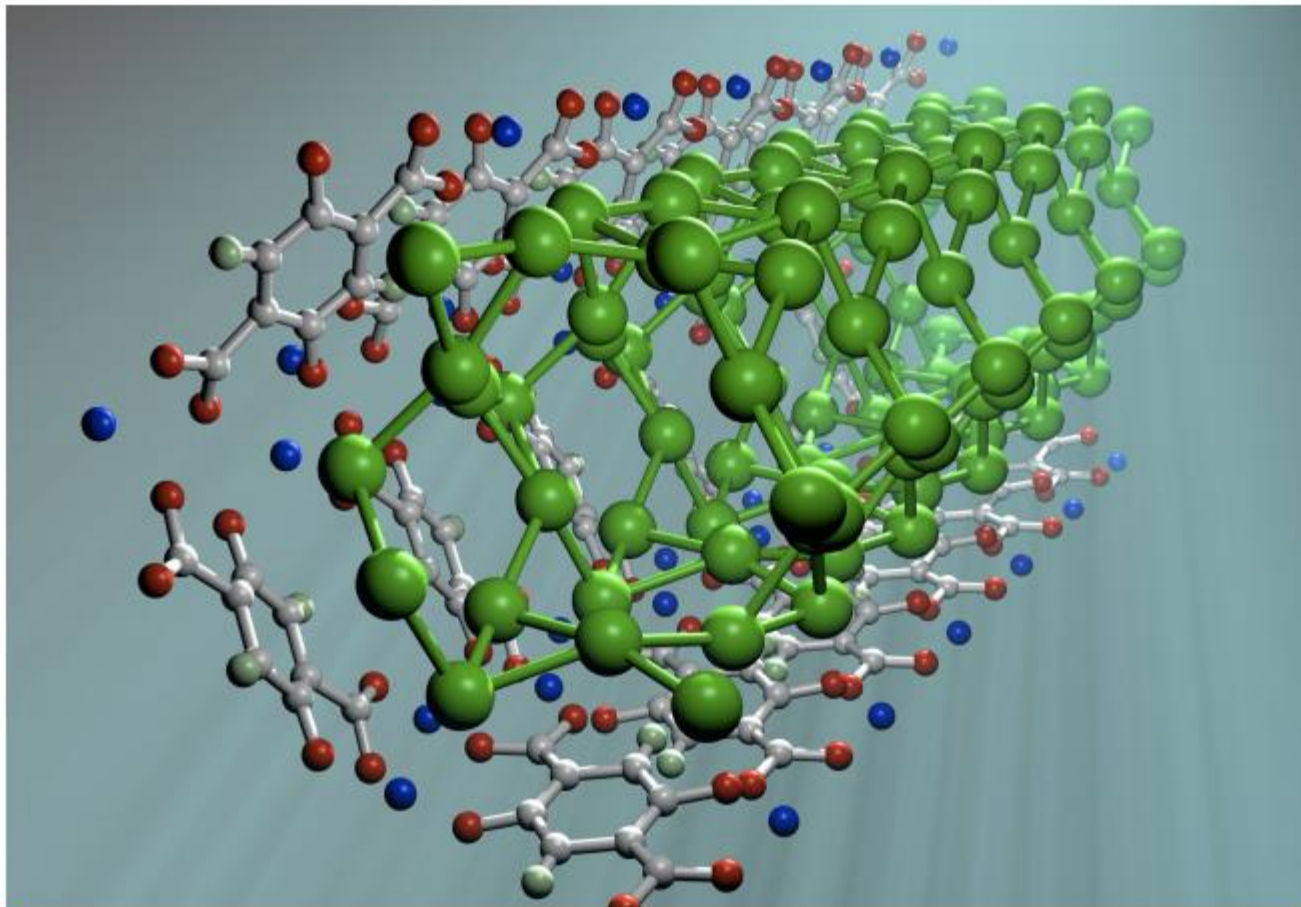

Hydrogen can be stored on the surfaces of solids by adsorption. In adsorption, hydrogen associates with the surface of a material either as hydrogen molecules (H_2) or hydrogen atoms (H). This figure depicts hydrogen adsorption within MOF-74.

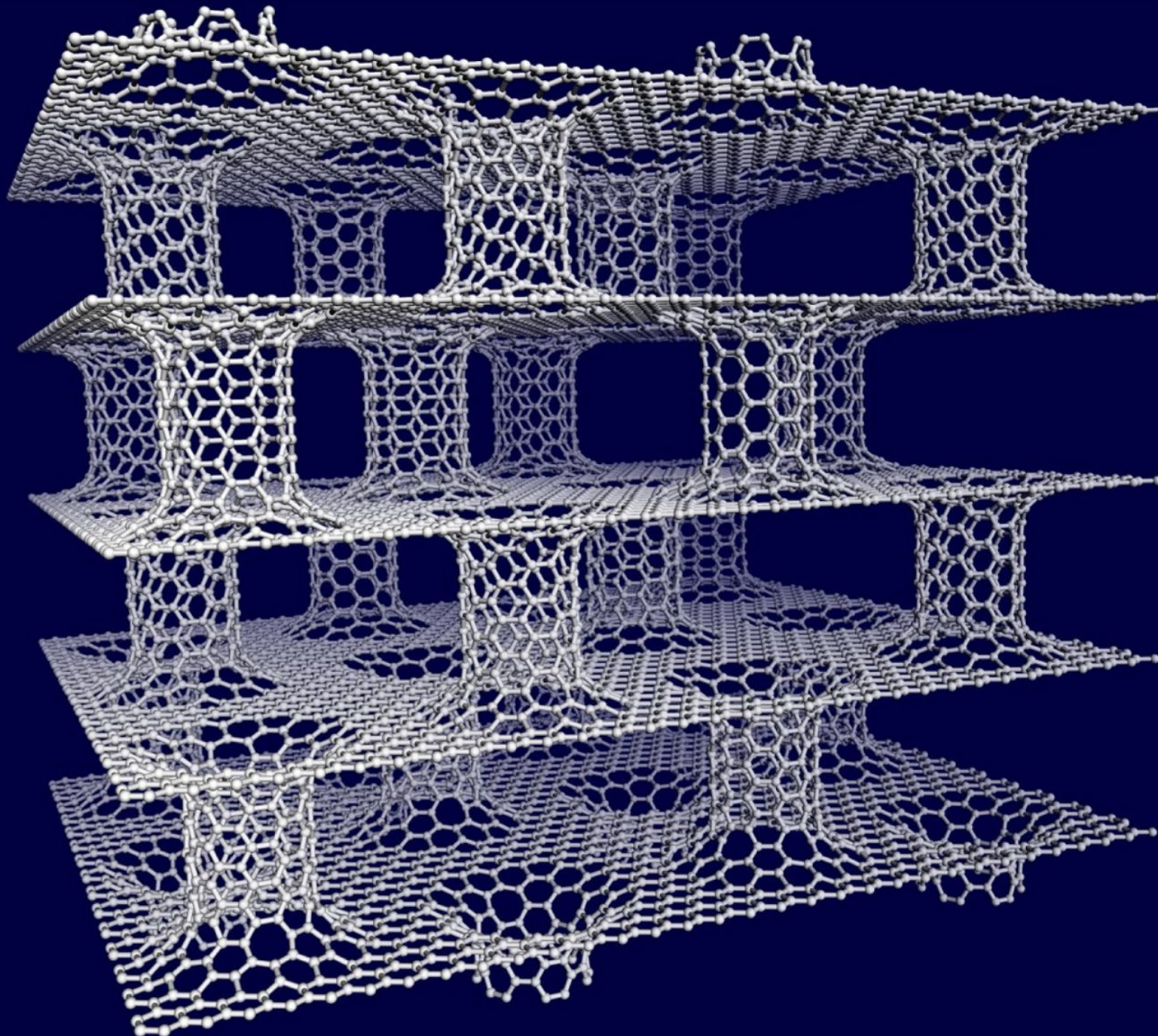

**Designing
novel
carbon
nano-
structures
for
hydrogen
storage**

Pillared graphene consists of CNTs and graphene sheets combined to form a 3D network nanostructure.

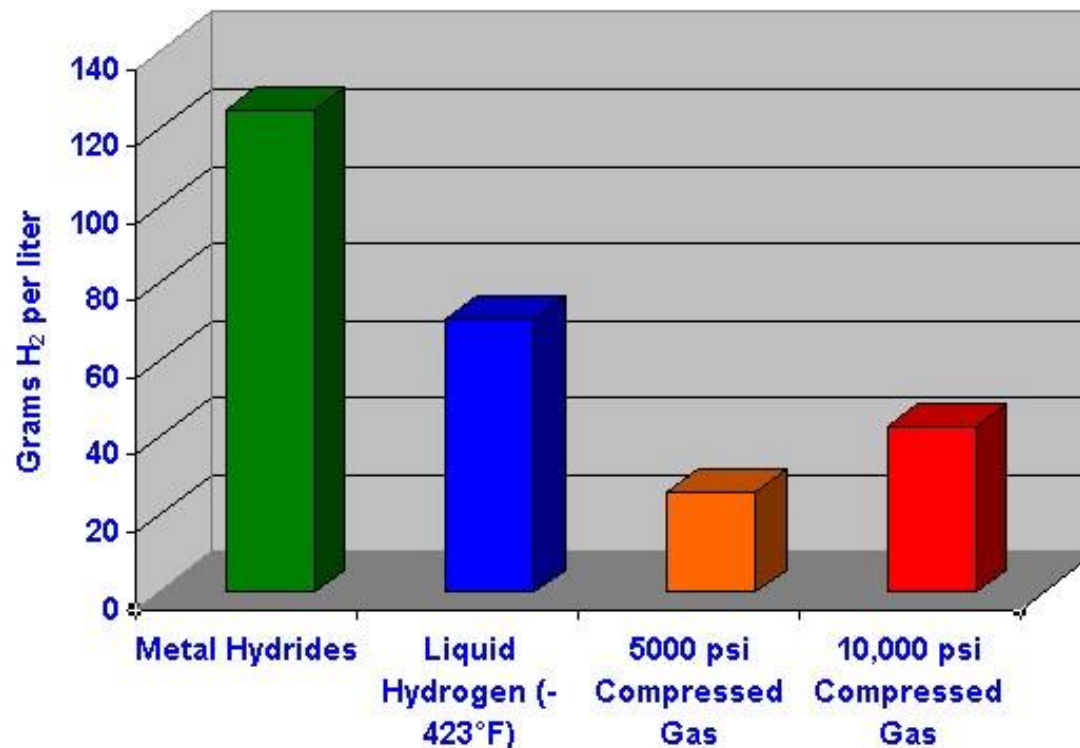

Mjerne jedinice za tlak

	<u>paskal</u>	<u>bar</u>	<u>tehnička atmosfera</u>	<u>standardna atmosfera</u>	<u>torr (mm Hg)</u>	<u>funta sile po četvornom palcu</u>
1 Pa	≡ 1 N/m ²	= 10 ⁻⁵ bar	≈ 10,197 · 10 ⁻⁶ at	≈ 9,8692 · 10 ⁻⁶ atm	≈ 7,5006 · 10 ⁻³ torr	≈ 145,04 · 10 ⁻⁶ psi
1 bar	= 100 000 Pa	≡ 10 ⁶ din/cm ²	≈ 1,0197 at	≈ 0,98692 atm	≈ 750,06 torr	≈ 14,504 psi
1 at	= 98 066,5 Pa	= 0,980665 bar	≡ 1 kp/cm ²	≈ 0,96784 atm	≈ 735,56 torr	≈ 14,223 psi
1 atm	= 101 325 Pa	= 1,01325 bar	≈ 1,0332 at	≡ 101 325 Pa	= 760 torr	≈ 14,696 psi
1 torr	≈ 133,322 Pa	≈ 1,3332 · 10 ⁻³ bar	≈ 1,3595 · 10 ⁻³ at	≈ 1,3158 · 10 ⁻³ atm	≡ 1 mmHg	≈ 19,337 · 10 ⁻³ psi
1 psi	≈ 6894,76 Pa	≈ 68,948 · 10 ⁻³ bar	≈ 70,307 · 10 ⁻³ at	≈ 68,046 · 10 ⁻³ atm	≈ 51,715 torr	≡ 1 lbf/in ²

Status of Hydrogen Storage Technologies

The current status in terms of weight, volume, and cost of various hydrogen storage technologies is shown below.

These values are estimates from storage system developers and the R&D community.

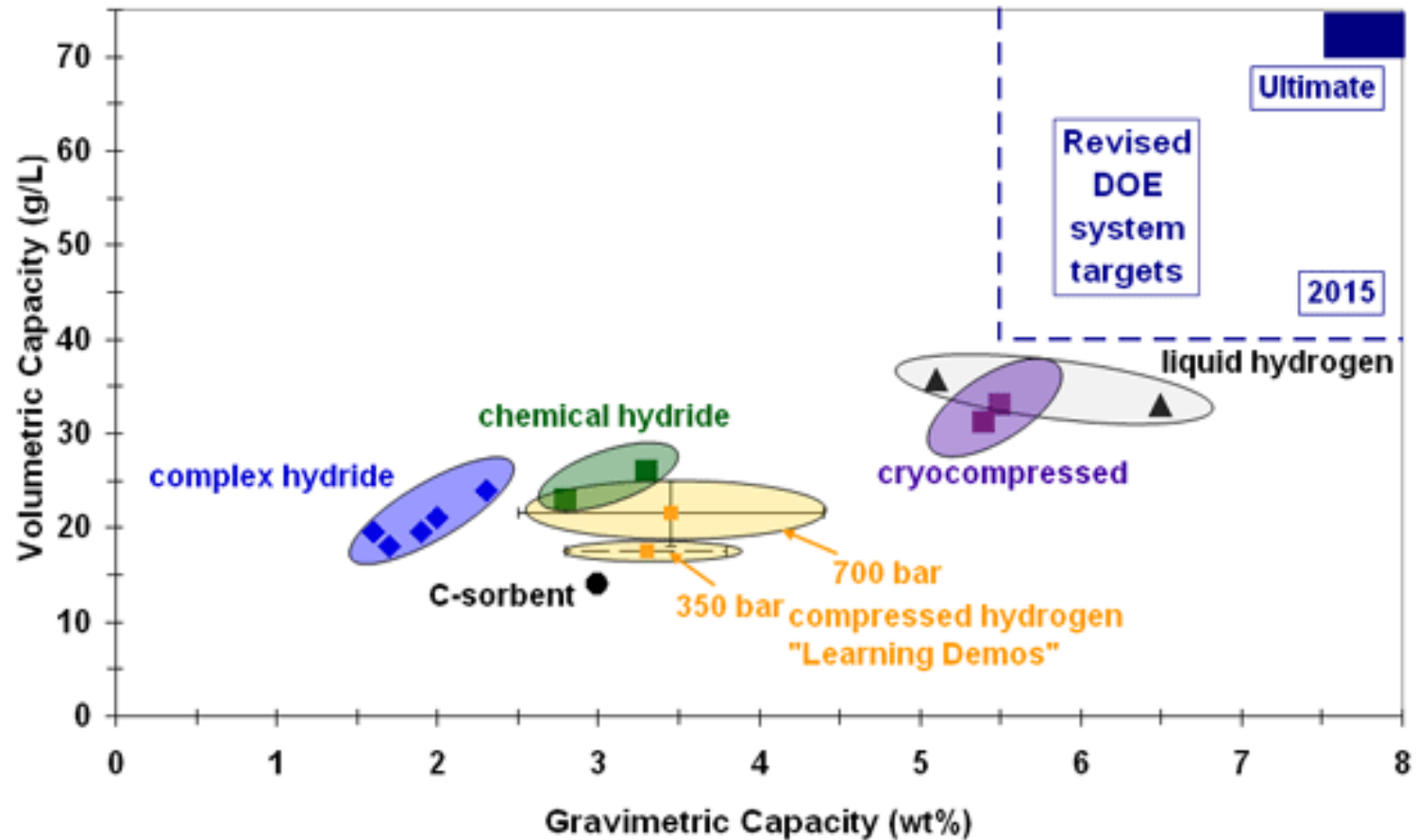

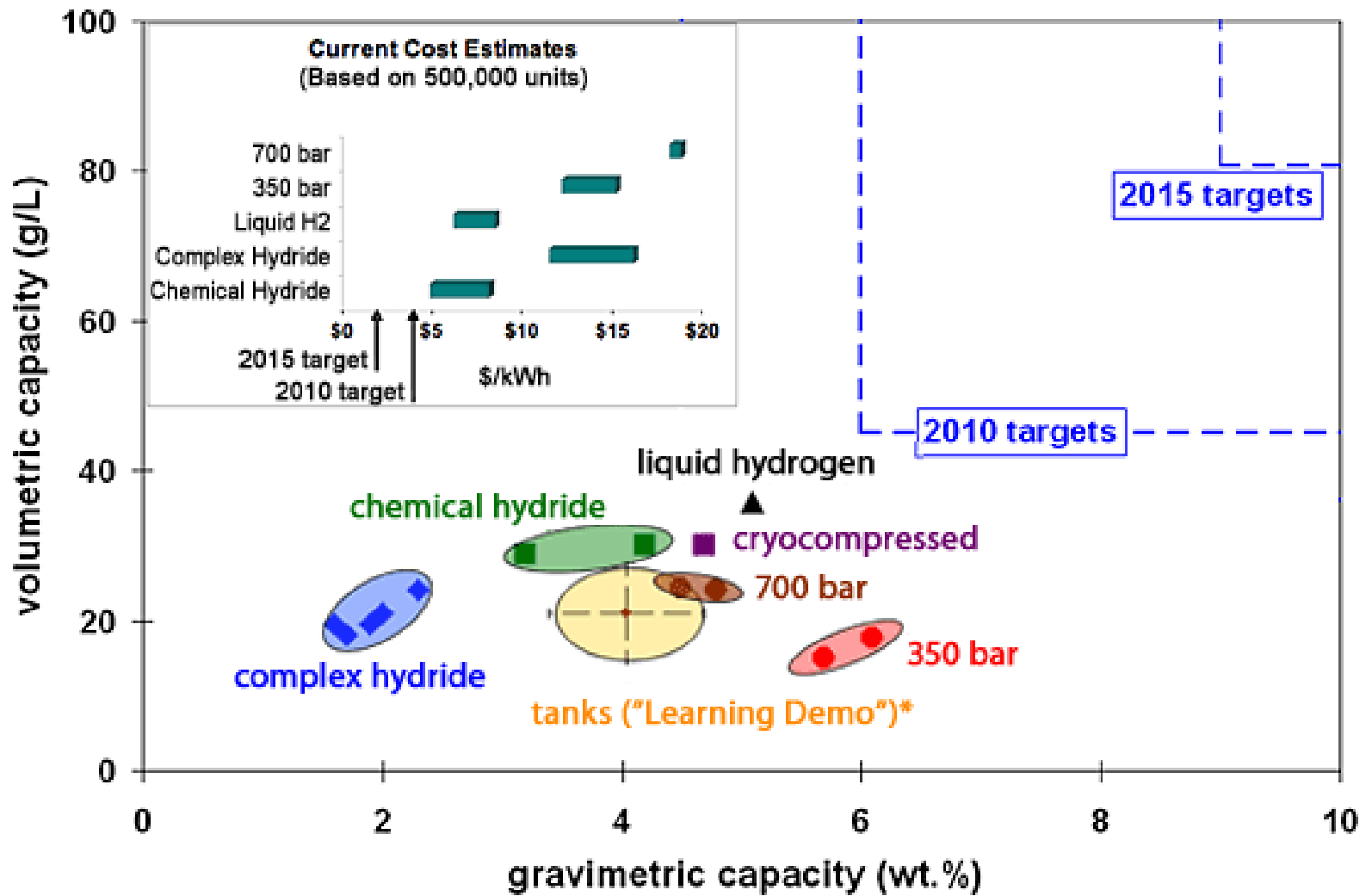

Hydrogen storage density cost graph

Skladištenje vodika

- Tekući vodik:
 - $T_v = 20,39$ K pri $p = 1$ bar
 - potrebno mnogo energije za ukapljivanje
 - kompresija
 - hlađenje tekućim dušikom
 - ekspanzija u turbinama
 - vodik difundira kroz stijenku spremnika
 - + jednom ukapljen, tekući vodik se lako transportira i upotrebljava
 - + spremnici vodika mogu biti i do 10 puta veći od spremnika benzina iste mase



Liquid Hydrogen Tanks

The energy density of hydrogen can be improved by storing hydrogen in a liquid state. However, the issues with LH₂ tanks are hydrogen boil-off, the energy required for hydrogen liquefaction, volume, weight, and tank cost. **The energy requirement for hydrogen liquefaction is high; typically, 30% of the heating value of hydrogen is required for liquefaction.**

New approaches that can lower these energy requirements and thus the cost of liquefaction are needed. Hydrogen boil-off must be minimized or eliminated for cost, efficiency, and vehicle-range considerations, as well as for safety considerations when vehicles are parked in confined spaces. Insulation is required for LH₂ tanks, and this reduces system gravimetric and volumetric capacity.

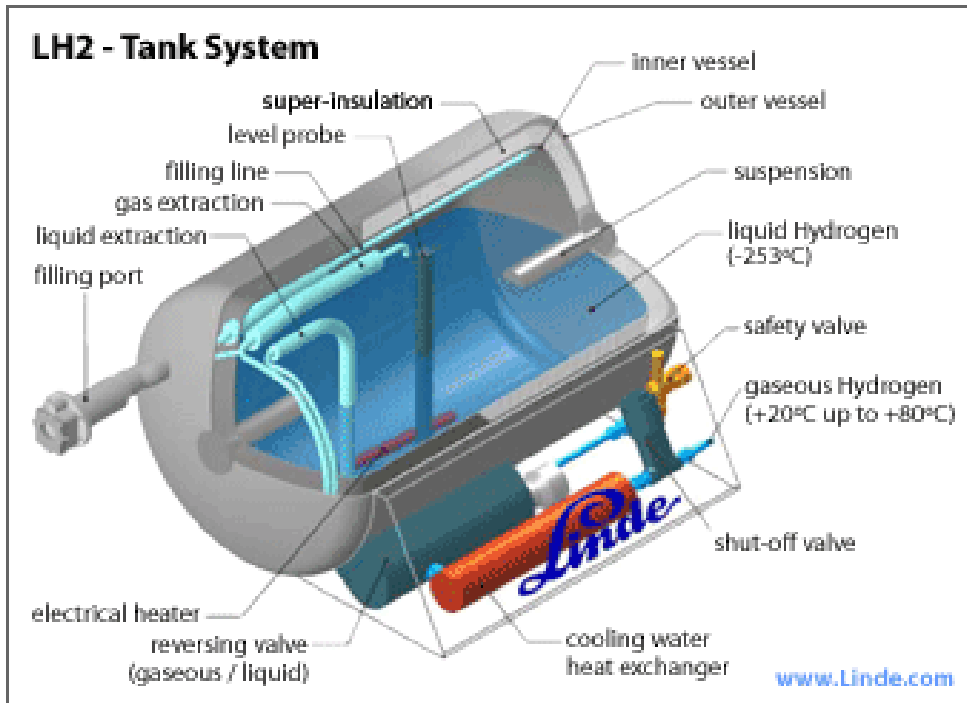

Liquid hydrogen (LH₂) tanks can store more hydrogen in a given volume than compressed gas tanks.

The volumetric capacity of liquid hydrogen is **0.070 kg/L**, compared to **0.030 kg/L** for 10,000-psi (700 bar) gas tanks.

Skladištenje vodika

- Plinoviti H₂ pod visokim tlakom

- najčešća metoda skladištenja

Čelični i aluminijski spremnici - sve manje u uporabi.

Kompozitni spremnici:

- aluminijeva slitina višeslojno je prevučena kompozitnim materijalom koji sadrži ugljikova vlakna
- slojevi kompozita slijepljeni su epoksidnom smolom i nosioci su čvrstoće spremnika
- tlak: 350 barg
(barg = tlak u bar + atmosferski tlak)

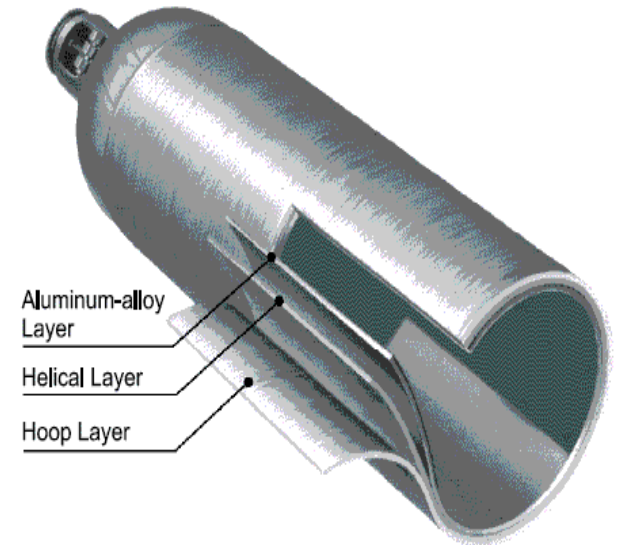

Compressed Hydrogen Gas Tank

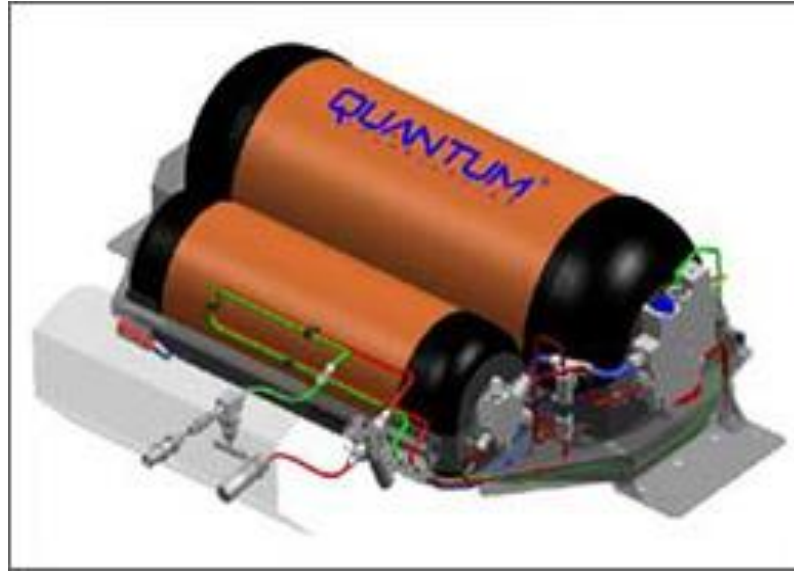

The energy density of gaseous hydrogen can be improved by storing hydrogen at higher pressures. **This higher pressure requires material and design improvements in order to ensure tank integrity.** Advances in compression technologies are also required to improve efficiencies and reduce the cost of producing high-pressure hydrogen.

Carbon fiber-reinforced 5000-psi (350 bar) and 10,000-psi (700 bar) compressed hydrogen gas tanks are under development.

Such tanks are already in use in prototype hydrogen-powered vehicles.

The **inner liner** of the tank is a high-molecular-weight polymer that serves as a hydrogen gas permeation barrier.

A carbon fiber-epoxy resin composite shell is placed over the liner and constitutes the gas pressure load-bearing component of the tank. Finally, an **outer shell** is placed on the tank for impact and damage resistance.

The pressure regulator for the 10,000-psi tank is located in the interior of the tank.

There is also an in-tank gas temperature sensor to monitor the tank temperature during the gas-filling process when tank heating occurs.

Two approaches are being pursued to increase the gravimetric and volumetric storage capacities of compressed gas tanks from their current levels.

1.

The first approach involves **cryo-compressed tanks**.

This is based on the fact that, at fixed pressure and volume, gas tank volumetric capacity increases as the tank temperature decreases.

Thus, by cooling a tank from room temperature to liquid nitrogen temperature (77 °K), its volumetric capacity will increase by a factor of 4, although system volumetric capacity will be less than this due to the increased volume required for the cooling system.

2.

The second approach involves the development of **conformable tanks**.

Present liquid gasoline tanks in vehicles are highly conformable in order to take maximum advantage of available vehicle space.

Concepts for conformable tank structures are based on the location of structural supporting walls.

Internal cellular-type load bearing structures may also be a possibility for greater degrees of conformability.

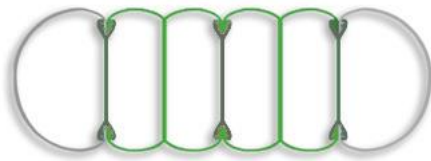

Compressed hydrogen tanks [5000 psi (350 bar) and 10,000 psi (700 bar)] have been certified worldwide according to ISO 11439 (Europe), NGV-2 (U.S.), and Reijikijun Betten (Iceland) standards and approved by TUV (Germany) and The High-Pressure Gas Safety Institute of Japan (KHK). Tanks have been demonstrated in several prototype fuel cell vehicles and are commercially available. Composite, 10,000-psi tanks have demonstrated a 2.35 safety factor (23,500 psi burst pressure) as required by the European Integrated Hydrogen Project specifications.

Diagram of Fords F150 fitted with Conventional Propane Tank vs CT

○ Conventional Propane Tank | ■ PPI's Conformable Propane Tank

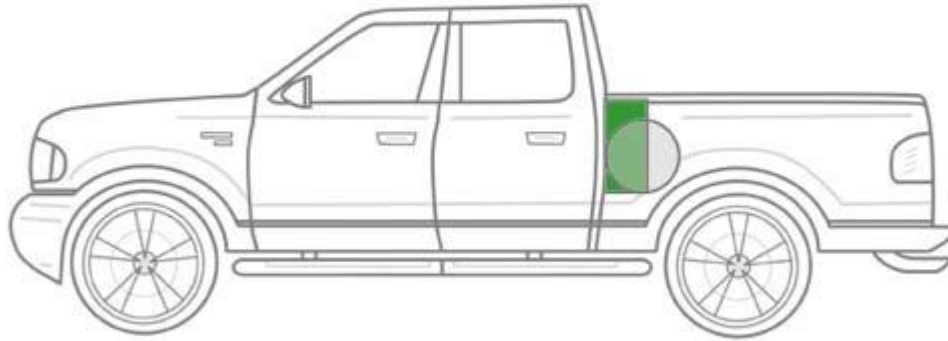

Round Tank 406mm x 1.320 = 95 litres Takes up 22% of tray space
CT 228/4 533mm x 1.320mm = 105 litres Takes up 12% of tray space

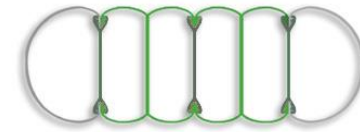

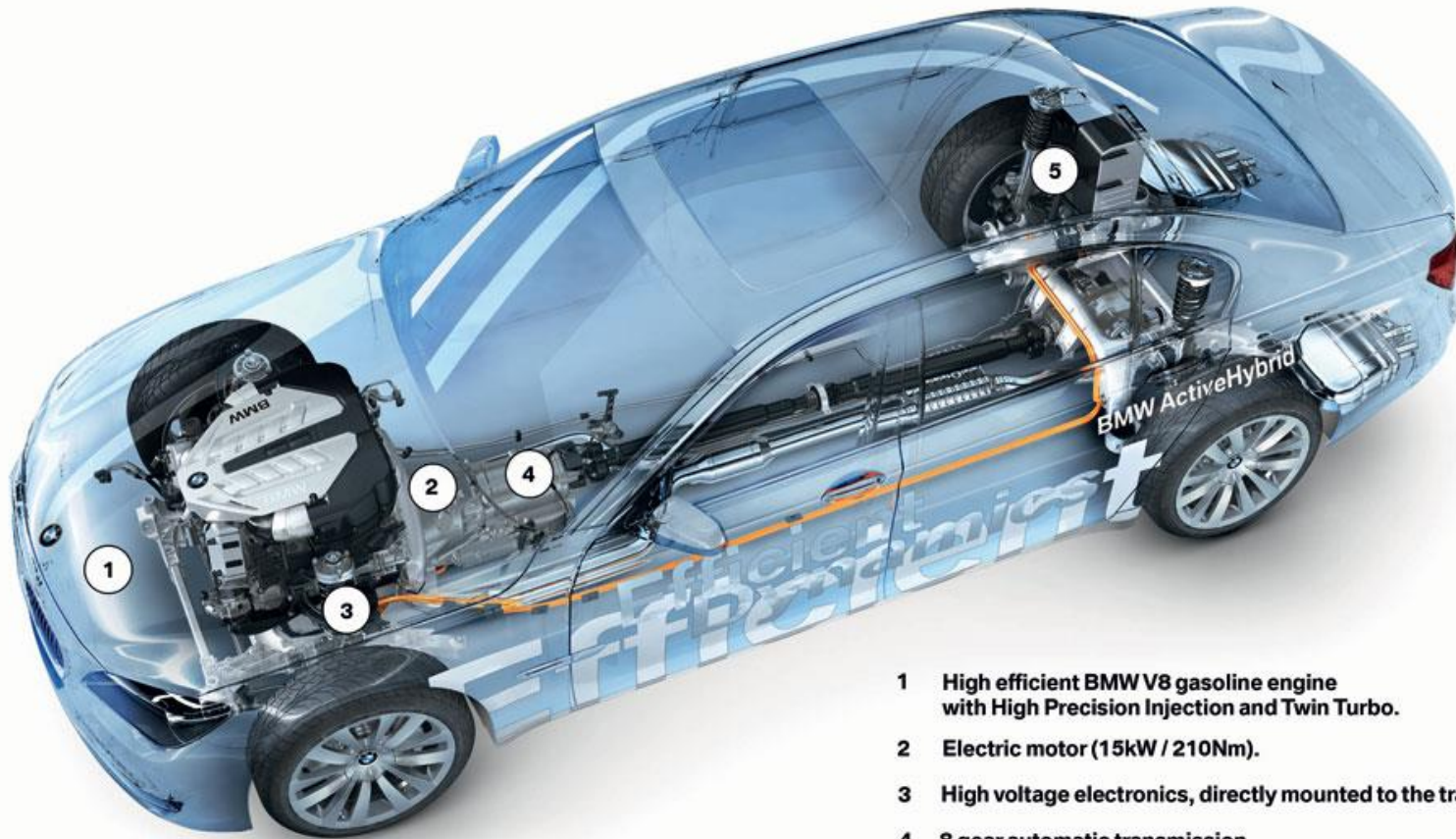

- 1 High efficient BMW V8 gasoline engine with High Precision Injection and Twin Turbo.**
- 2 Electric motor (15kW / 210Nm).**
- 3 High voltage electronics, directly mounted to the transmission box.**
- 4 8 gear automatic transmission.**
- 5 Lithium-ion battery (120 Volts).**

BMW LH2 hydrogen storage tank

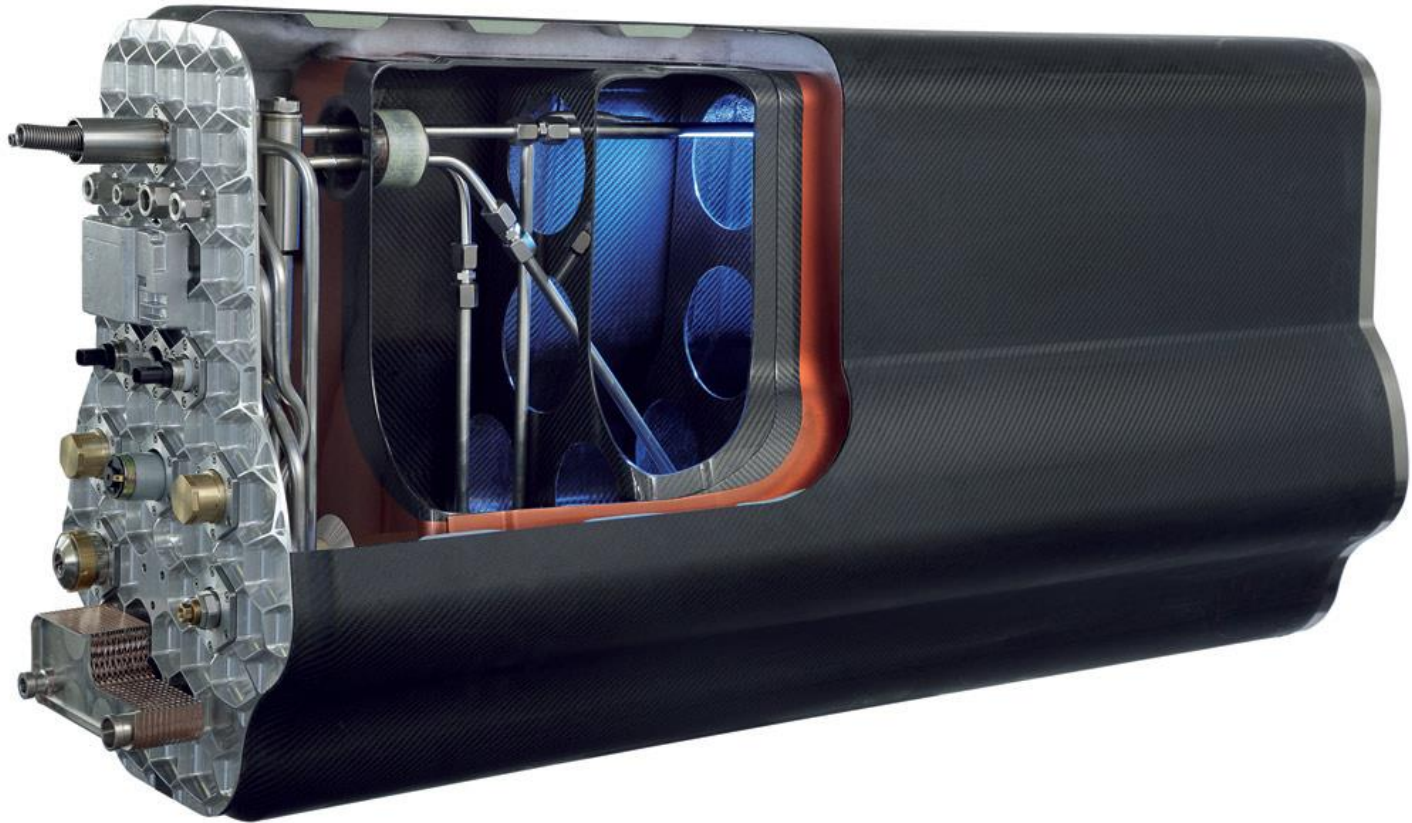

The BMW LH2 hydrogen storage tank, developed in collaboration with partners from the European aerospace industry, is made of composite materials and its weight is up to a third of the weight of a conventional cylindrical steel tank.

The subsidiary systems of the BMW LH2 storage tank are integrated inside the casing, taking up less room in the car and making the maintenance much easier.

- with 10 kg of hydrogen, it could allow a range well in excess of 500 km in a future vehicle

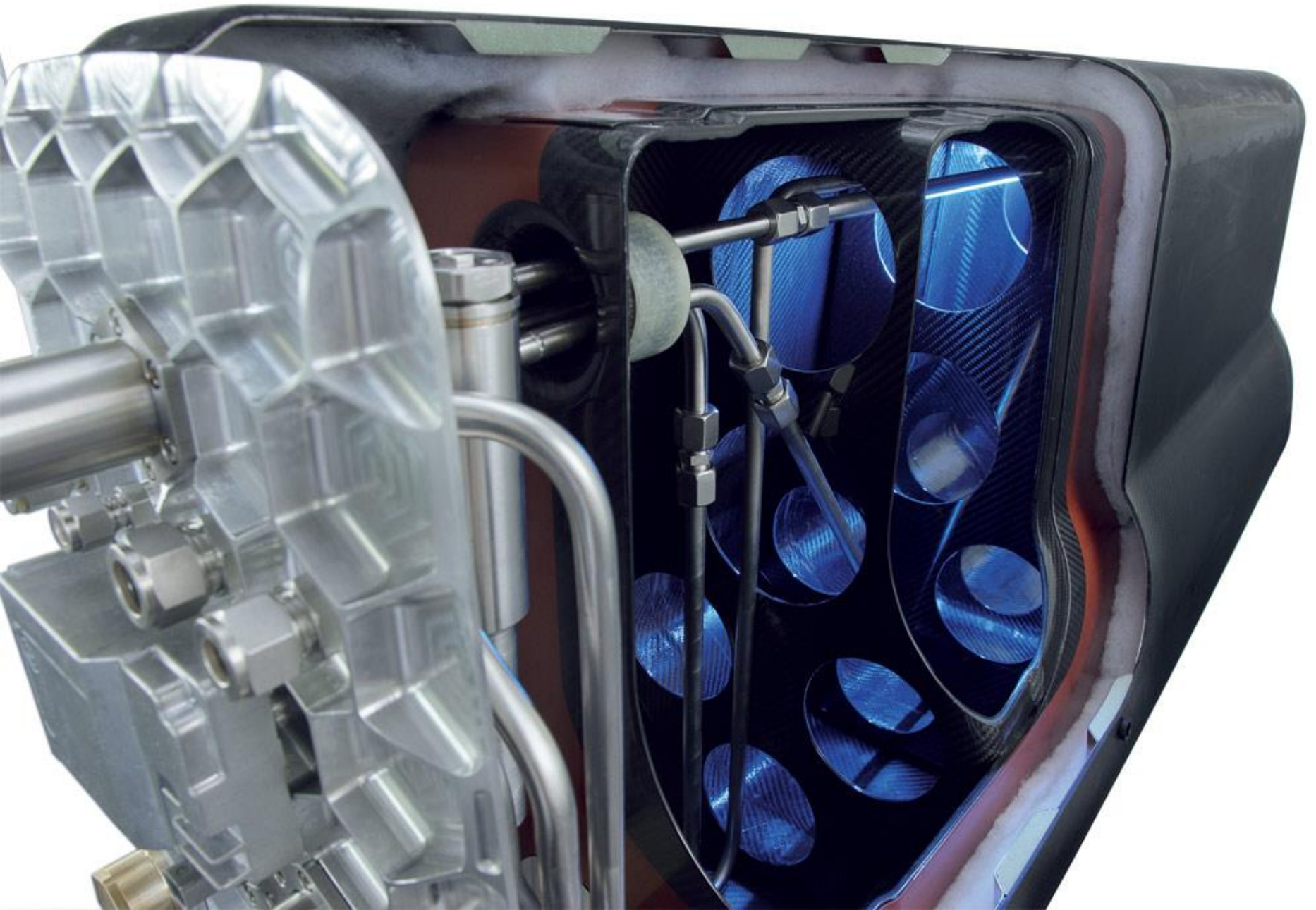

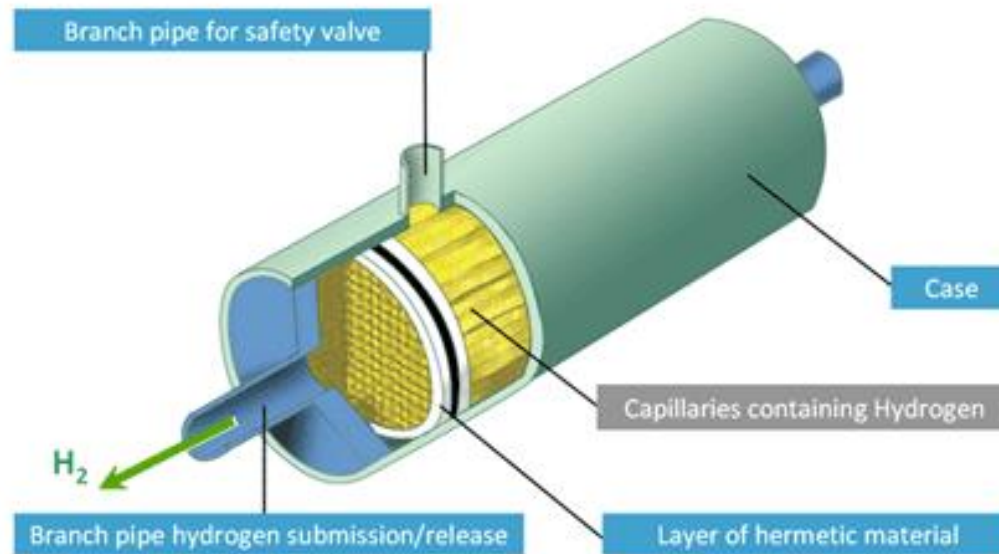

Hydrogen is stored in lightweight bundles of thin, strong glass tubes called capillary arrays.



U.S. Department of Energy
Energy Efficiency and Renewable Energy

Unacceptable Hydrogen Storage Option



"It runs on hydrogen."

Materials-Based Hydrogen Storage

Absorption. In absorptive hydrogen storage, hydrogen is absorbed directly into the bulk of the material. In simple crystalline metal hydrides, this absorption occurs by the **incorporation of atomic hydrogen into interstitial sites in the crystallographic lattice structure**.

Adsorption. Adsorption may be subdivided into physisorption and chemisorption based on the energetics of the adsorption mechanism. Physisorbed hydrogen is more weakly and energetically bound to the material than is chemisorbed hydrogen.

Sorptive processes typically require highly porous materials to maximize the surface area available for hydrogen sorption to occur and to allow for easy uptake and release of hydrogen from the material.

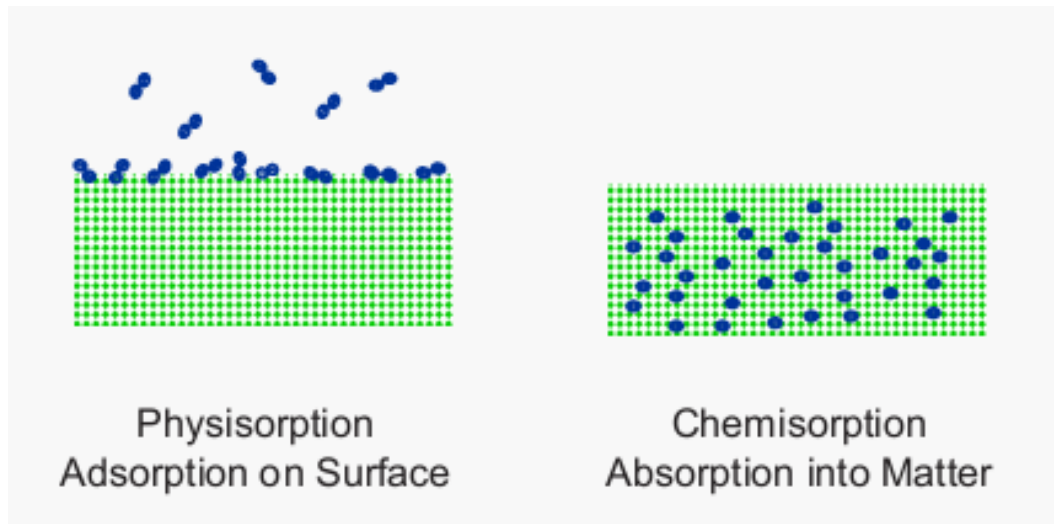

Materials-Based Hydrogen Storage

Chemical reaction.

The chemical reaction route for hydrogen storage involves displacive chemical reactions for both hydrogen generation and hydrogen storage.

For reactions that may be [reversible](#) on-board a vehicle, [hydrogen generation and hydrogen storage](#) take place by a **simple reversal of the chemical reaction as a result of modest changes in the temperature and pressure.**

Sodium alanate-based complex metal hydrides are an example.

In many cases, the hydrogen generation reaction is [not reversible](#) under modest temperature/pressure changes. Therefore, although hydrogen can be generated on-board the vehicle, getting hydrogen back into the starting material must be done off-board. Sodium borohydride is an example.

Materials-based storage activities are categorized as follows:

- [Metal hydrides](#) - reversible solid-state materials that can be regenerated on-board
- [Chemical hydrides](#) - hydrogen is released via chemical reaction (usually with water); the "spent fuel" or byproduct is regenerated off-board
- [Carbon-based materials](#) - reversible solid-state materials that can be regenerated on-board

Overview of solid hydrogen storage options

Carbon and other HSA materials*

- Activated charcoals
- Nanotubes
- Graphite nanofibers
- MOFs, Zeolites, etc.
- Clathrate hydrates

Chemical hydrides (H₂O-reactive)

- Encapsulated NaH
- LiH & MgH₂ slurries
- CaH₂, LiAlH₄, etc

Rechargeable hydrides

- Alloys & intermetallics
- Nanocrystalline
- Complex

Chemical hydrides (thermal)

- Ammonia borozane
- Aluminum hydride

* HSA = high surface area

Selected H₂-storage system and media targets for fuel cell vehicles†

Property	Units	2010 USA	2007 Japan	2006 IEA*
System density (by weight)	wt.% H ₂	6	3	-
System density (by volume)	kg H ₂ /m ³	45	-	-
System cost	US\$/kg H ₂	133	-	-
Refuelling time	minutes	3	-	-
Medium density (by weight)	wt.% H ₂	-	5.5	5.0
H ₂ liberation temperature	°C	-	150	80

† 500 km range = ca. 5-13 kg stored H₂.

* IEA HIA Task 17.

6. The Research Council of Norway, PO Box 2700, St. Hanshaugen NO-0131 Oslo, Norway.

7. IEA HIA Task 17 Operating Agent, SunaTech, Inc., 113 Kraft Pl., Ringwood, NJ 07456, USA.

8. Institute for Energy Technology, PO Box 40, NO-2027 Kjeller, Norway.

Hydriding Reactions

- Electrochemical: $M + xH_2O + xe^- \leftrightarrow MH_x + xOH^-$
- Gas Phase: $M + x/2H_2 \leftrightarrow MH_x + \text{heat}$

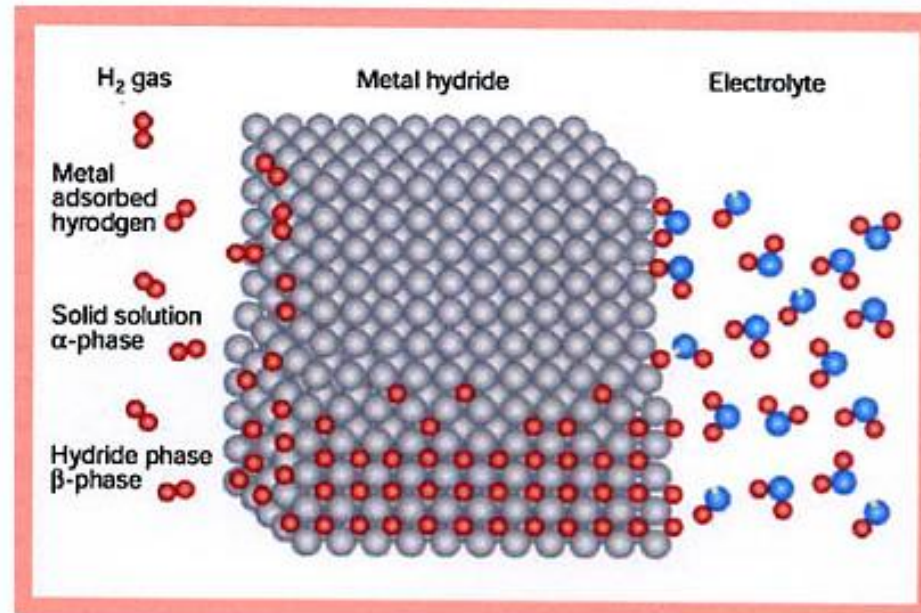

Schematic of a rechargeable metal hydride battery

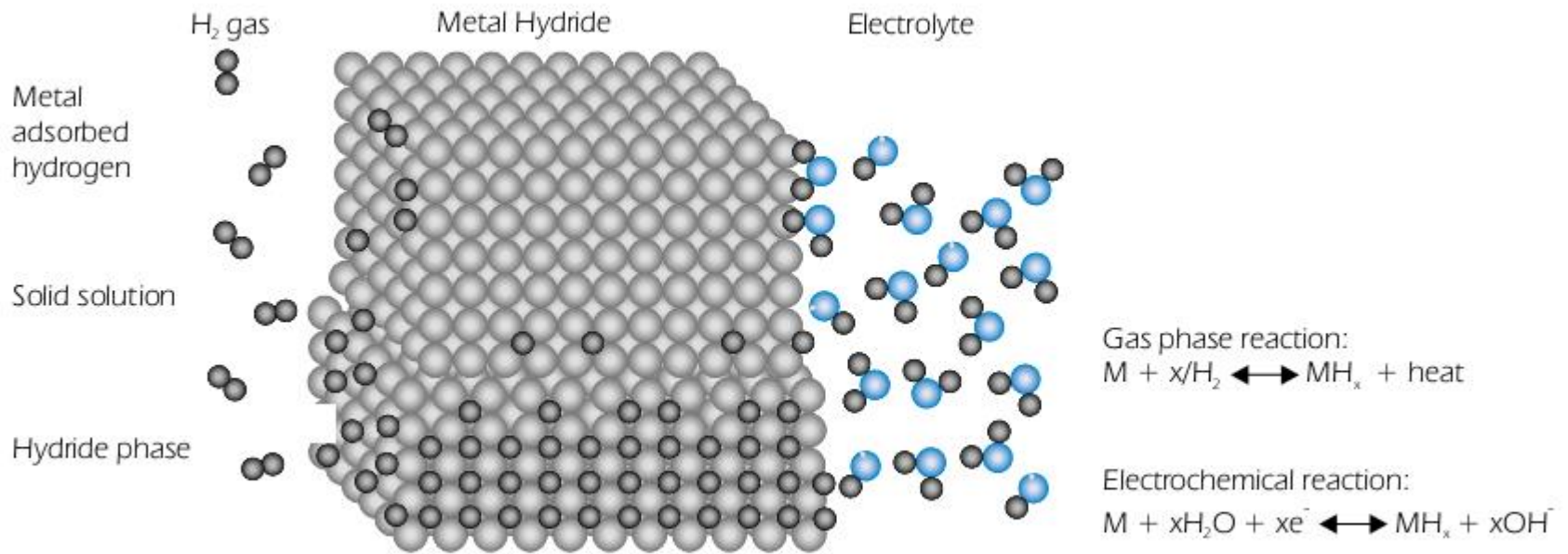

Source: Schlapbach, Nature, 2001 [1].

Metal hydride family tree

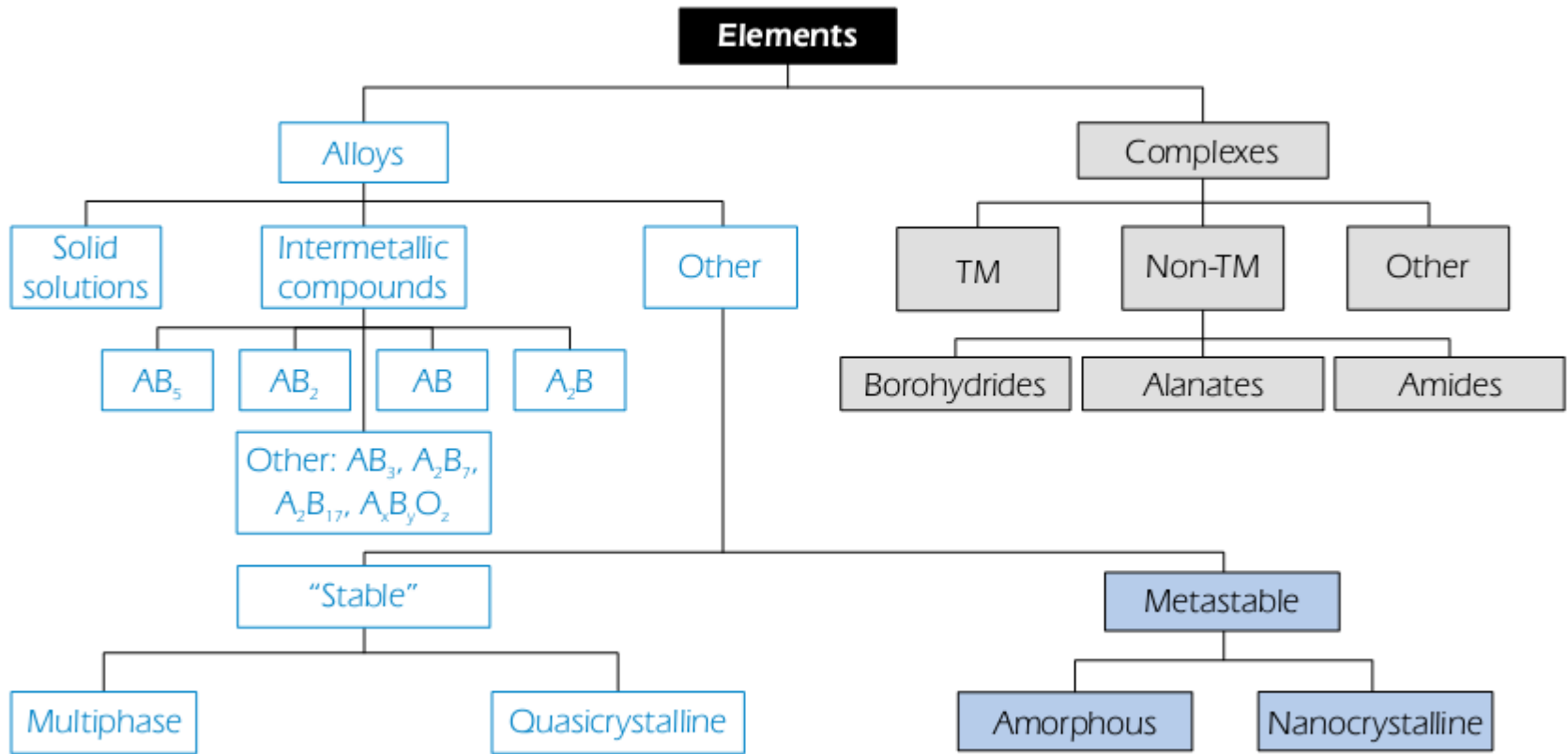

Source: Sandrock, after JALCOM, 1999 [6].

Alانات: Key properties of the most-common types

Type	Storage density*, wt.% H ₂	Desorption temperature, °C
LiAlH ₄	10.6	190
NaAlH ₄	7.5	100
Mg(AlH ₄)	9.3	140
Ca(AlH ₄)	7.8	> 230

* Theoretical maximum.

Borohydrides: Key properties of most common types

Type	Storage density*, wt.% H ₂	Desorption temperature, °C
LiBH ₄	18.5	300
NaBH ₄	10.6	350
KBH ₄	7.4	125
Be(BH ₄) ₂	20.8	125
Mg(BH ₄) ₂	14.9	320
Ca(BH ₄) ₂	11.6	260

* Theoretical maximum.

Hydrolysis reaction for selected H₂O-reactive chemical hydrides

Hydrolysis reaction	Storage density*, wt.% H ₂
$\text{LiH} + \text{H}_2\text{O} \Rightarrow \text{H}_2 + \text{LiOH}$	7.8
$\text{NaH} + \text{H}_2\text{O} \Rightarrow \text{H}_2 + \text{NaOH}$	4.8
$\text{MgH}_2 + 2\text{H}_2\text{O} \Rightarrow 2\text{H}_2 + \text{Mg(OH)}_2$	6.5
$\text{CaH}_2 + 2\text{H}_2\text{O} \Rightarrow 2\text{H}_2 + \text{Ca(OH)}_2$	5.2

* Theoretical maximum.

Decomposition reactions for thermal chemical hydrides

Decomposition reaction	Storage density*, wt.% H ₂	Temperature†, °C
$\text{NH}_4\text{BH}_4 \Rightarrow \text{NH}_3\text{BH}_3 + \text{H}_2$	6.1	< 25
$\text{NH}_3\text{BH}_3 \Rightarrow \text{NH}_2\text{BH}_2 + \text{H}_2$	6.5	< 120
$\text{NH}_2\text{BH}_2 \Rightarrow \text{NHBH} + \text{H}_2$	6.9	> 120
$\text{NHBH} \Rightarrow \text{BN} + \text{H}_2$	7.3	> 500

* Theoretical maximum.

† Decomposition temperature.

Source: Autrey et al, DOE EERE Program Review, 2004 [7].

CONCLUSIONS AND RECOMENDATIONS

Gaseous H₂ Storage:

- Status: Commercially available, but costly.
- Best option: C-fibre composite vessels (6-10 wt% H₂ at 350-700 bar).
- R&D issues: Fracture mechanics, safety, compression energy, and reduction of volume.

Liquid H₂ Storage:

- Status: Commercially available, but costly.
- Best option: Cryogenic insulated dewars (ca. 20 wt% H₂ at 1 bar and -253°C).
- R&D issues: High liquefaction energy, dormant boil off, and safety.

Solid H₂ Storage:

- Status: Very early development (many R&D questions).
- Best options: Too early to determine. Many potential options: Rechargeable hydrides, chemical hydrides (H₂O & thermally reactive), carbon, and other high surface area materials.
Most-developed option: Metal hydrides (potential for > 8 wt.% H₂ and > 90 kg/m³ H₂-storage capacities at 10-60 bar).
- R&D issues: Weight, lower desorption temperatures, higher desorption kinetics, recharge time and pressure, heat management, cost, pyrophoricity, cyclic life, container compatibility and optimisation.

Comparison of storage solutions available on the market

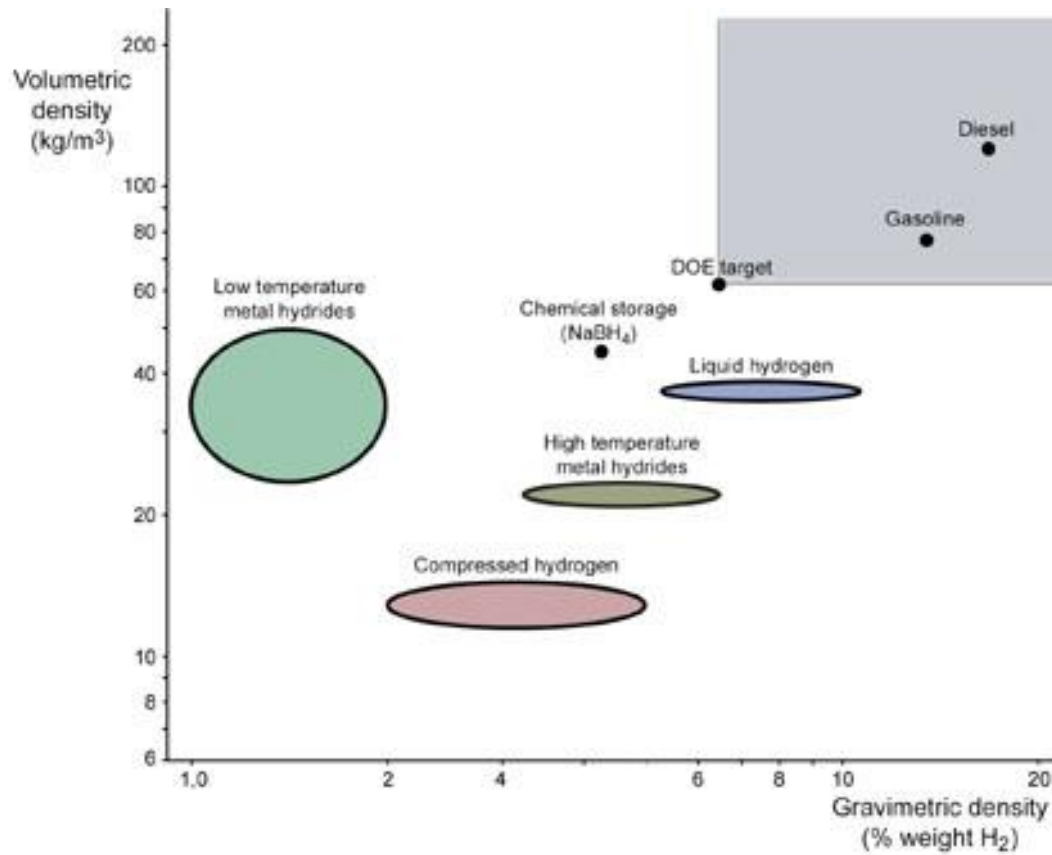

MOLECULAR HYDROGEN STORAGE IN LIGHT-ELEMENT COMPOUNDS

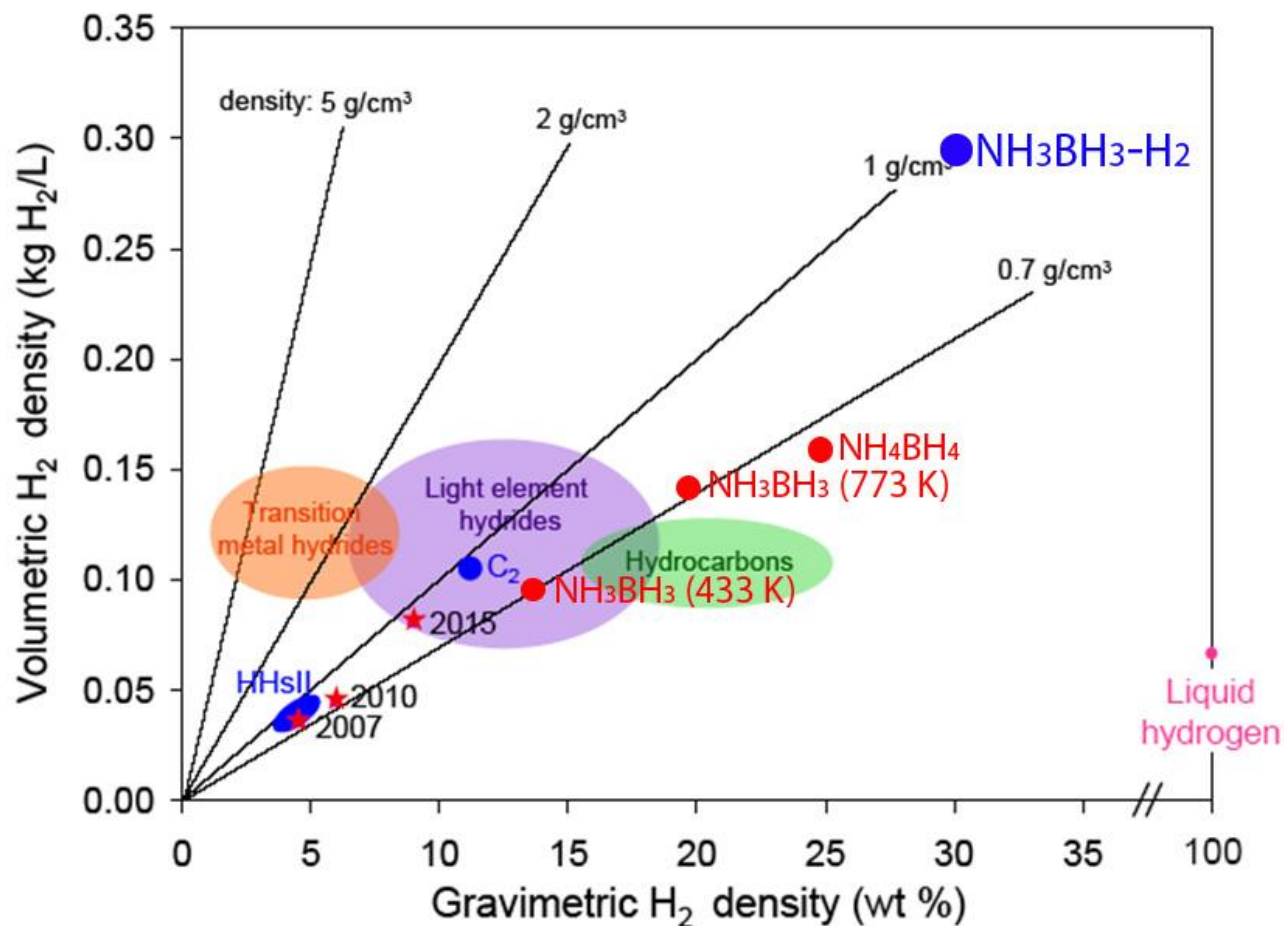

Ammonia borane (NH₃BH₃) is considered a promising chemical hydride for hydrogen storage exhibiting interesting behavior at variable temperature and pressure conditions.

Hydrogen Storage Challenges

For transportation, the overarching technical challenge for hydrogen storage is how to store the amount of hydrogen required for a conventional **driving range** (>300 miles) within the vehicular constraints of **weight, volume, efficiency, safety, and cost**.

Durability over the performance **lifetime** of these systems must also be verified and validated, and acceptable **refueling times** must be achieved.

Requirements for off-board bulk storage are generally less restrictive than on-board requirements;

for example, there may be no or less-restrictive weight requirements, but there may be volume or "footprint" requirements.

The key challenges include:

- **Weight and Volume.**

The weight and volume of hydrogen storage systems are **presently too high**, resulting in **inadequate vehicle range** compared to conventional petroleum fueled vehicles.

Materials and components are needed that allow compact, lightweight, hydrogen storage systems while enabling mile range greater than 300 miles in all light-duty vehicle platforms.

- **Efficiency.**

Energy efficiency is a challenge for all hydrogen storage approaches.

The energy required to get hydrogen in and out is an issue for reversible solid-state materials. Life-cycle energy efficiency is a challenge for chemical hydride storage in which the byproduct is regenerated off-board. In addition, the energy associated with compression and liquefaction must be considered for compressed and liquid hydrogen technologies.

- **Durability.**

Durability of hydrogen storage systems is inadequate. Materials and components are needed that allow hydrogen storage systems with a **lifetime of 1500 cycles**.

- **Refueling Time.**

Refueling times are too long. There is a need to develop hydrogen storage systems with refueling times of **less than three minutes over the lifetime of the system**.

- **Cost.**

The cost of on-board hydrogen storage systems is too high, particularly in comparison with conventional storage systems for petroleum fuels. Low-cost materials and components for hydrogen storage systems are needed, as well as low-cost, high-volume manufacturing methods.

- **Codes and Standards.**

Applicable codes and standards for hydrogen storage systems and interface technologies, which will facilitate implementation/commercialization and ensure safety and public acceptance, have not been established. **Standardized hardware and operating procedures, and applicable codes and standards, are required.**

- **Life-Cycle and Efficiency Analyses.**

There is a lack of analyses of the full life-cycle cost and efficiency for hydrogen storage systems.



Single-walled nanotube



Rope of single-walled nanotubes



Multi-walled nanotube

Representation of the carbon nanotube structures

The porosity of nanotubes is large. This property enables the adsorption of various gases including hydrogen.



Results indicate that carbon nanostructures are falling short of the DOE targets. Such structure as thus more likely to be inappropriate for hydrogen storage in transport applications.

Evaluation of the storage capacity of nanotubes with Monte-Carlo numerical simulations - results indicate that carbon single-walled nanotubes can store 0.22 % to 0.79 % weight (3.95 to 7.94 kg/m) of hydrogen at room temperature and under a pressure of 10 MPa.

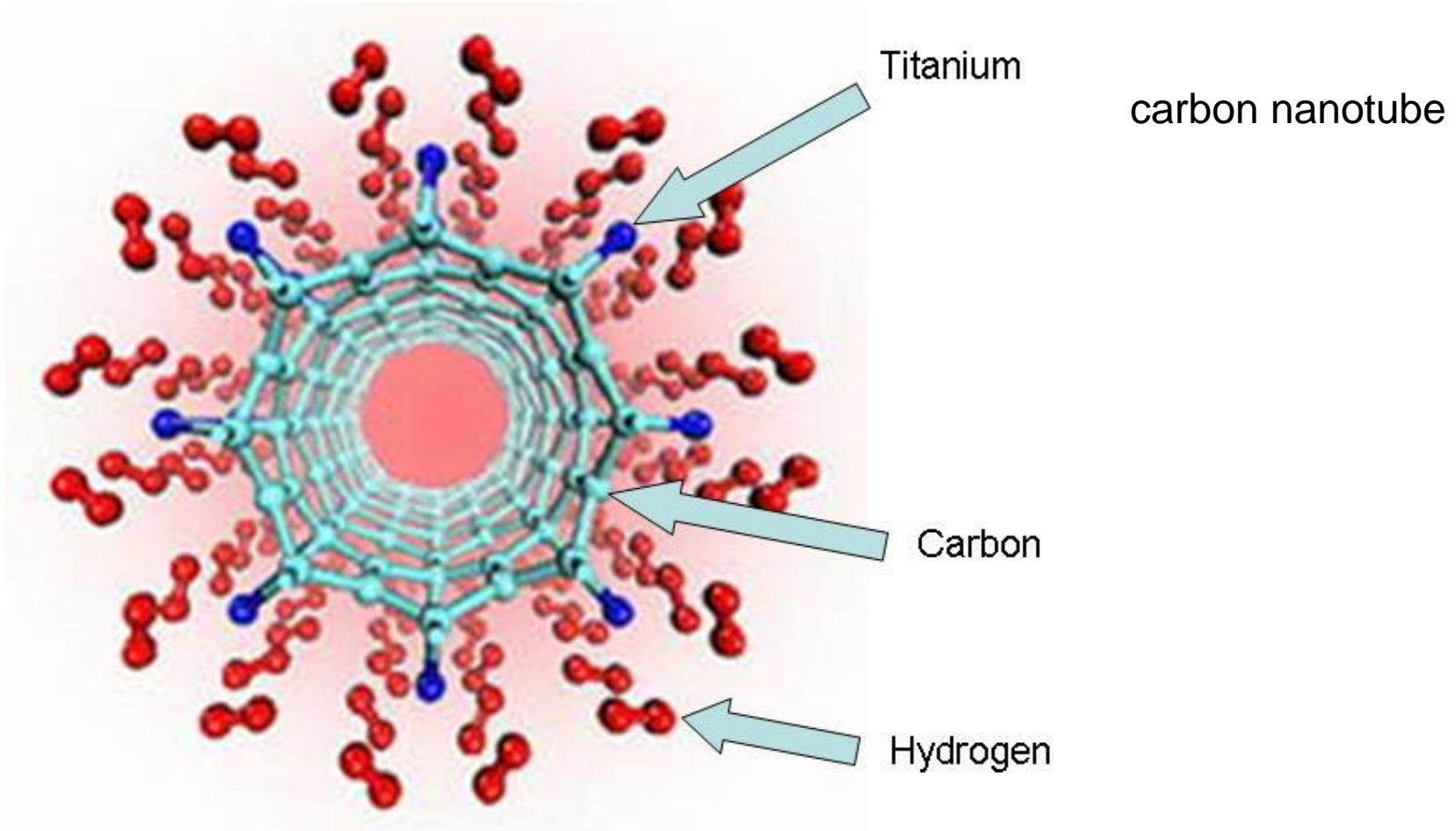

One method of storing hydrogen is the use of [nanotubes](#) to store hydrogen atoms on the outer surface then release them when needed

Metal-organic frameworks represent another class of synthetic porous materials that store hydrogen and energy at the molecular level.

MOFs are highly crystalline inorganic-organic hybrid structures that contain metal clusters or ions (secondary building units) as nodes and organic ligands as linkers. When guest molecules (solvent) occupying the pores are removed during solvent exchange and heating under vacuum, porous structure of MOFs can be achieved without destabilizing the frame and hydrogen molecules will be adsorbed onto the surface of the pores by physisorption.

Compared to traditional zeolites and porous carbon materials, MOFs have very high number of pores and surface area which allow higher hydrogen uptake in a given volume.

Thus, research interests on hydrogen storage in MOFs have been growing since 2003 when the first MOF-based hydrogen storage was introduced.

Since there are infinite geometric and chemical variations of MOFs based on different combinations of SBUs and linkers, many researches explore what combination will provide the maximum hydrogen uptake by varying materials of metal ions and linkers.

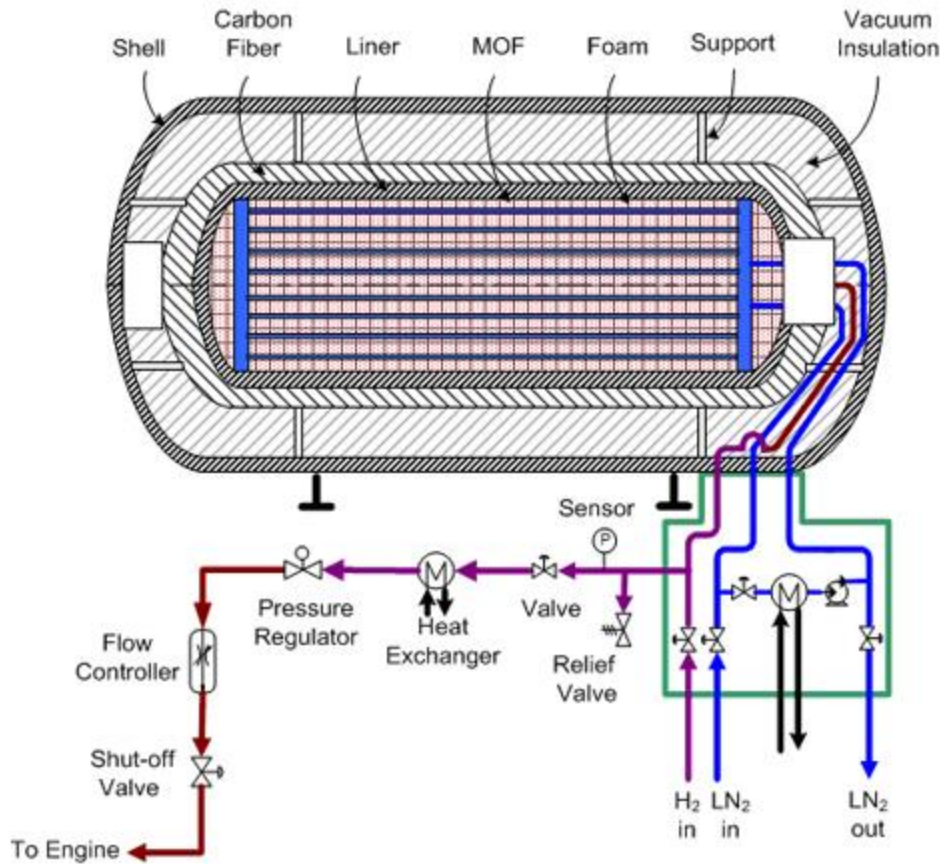

A schematic drawing of a MOF-177 On-Board Hydrogen Storage System.

Hydrogen Storage Systems Modeling and Analysis

Several different approaches are being pursued to develop on-board hydrogen storage systems for light-duty vehicle applications. The different approaches have different characteristics, such as:

- the thermal energy and temperature of charge and discharge
- kinetics of the physical and chemical process steps involved
- requirements for the materials and energy interfaces between the storage system and the fuel supply system on one hand, and the fuel user on the other

Berkeley Lab Scientists Achieve Breakthrough in Nanocomposite for High-Capacity Hydrogen Storage

March 14, 2011

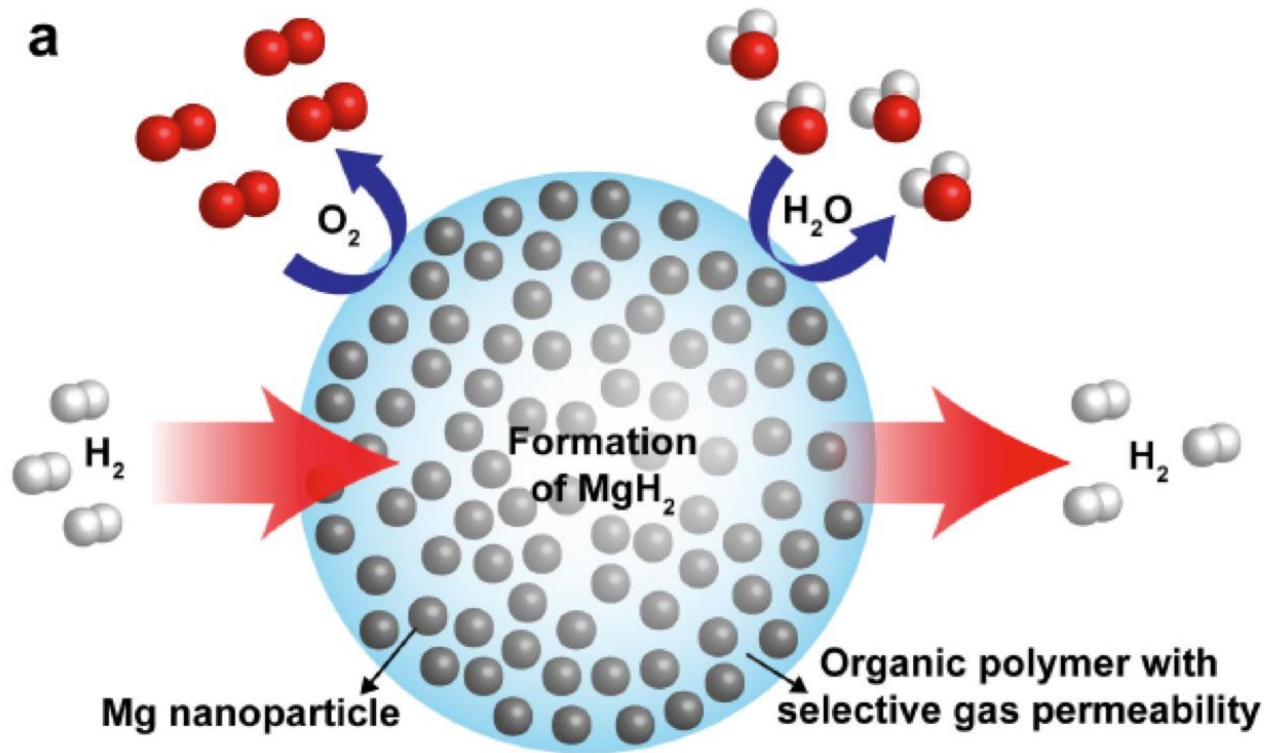

This schematic shows high-capacity magnesium nanocrystals encapsulated in a gas-barrier polymer matrix to create a new and revolutionary hydrogen storage composite material.

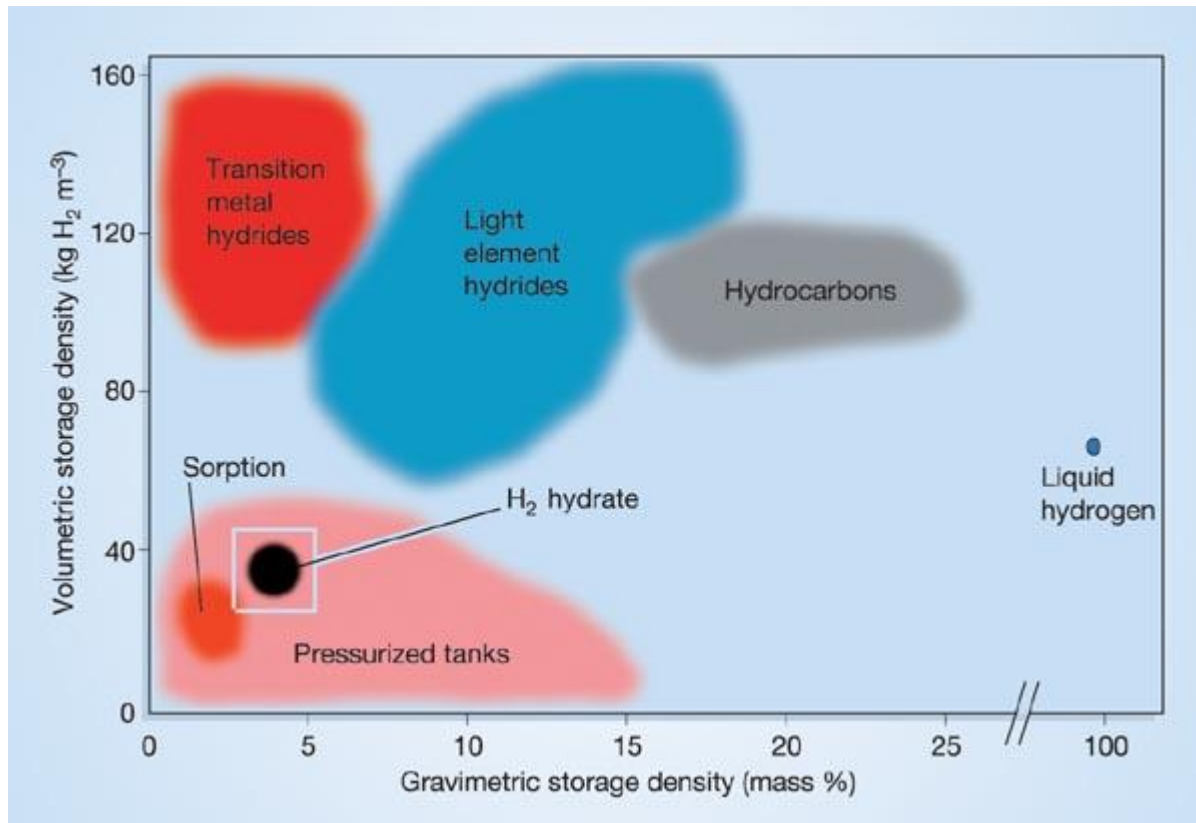

Volumetric (mass H_2 per unit volume of storage medium) versus gravimetric (% H_2 storage density) values for different hydrogen storage systems, showing the relative position of the hydrogen hydrate. The density of the H_2 hydrate has not yet been reported but can be estimated at around 0.83 g cm^{-3} . This brings the volumetric storage density to about 50% of that of liquid hydrogen. The thermodynamic properties of most of the hydrides in the upper field of the diagram make them unsuitable for reversible hydrogen storage. Hydrocarbons need re-forming and liquid hydrogen needs a refrigeration system (not included in the calculation). Weights and volumes of pressure tanks for pressurized storage are included; actual storage densities depend on tank type.

Chemical Hydrogen Storage

The term "chemical hydrogen storage" is used to describe storage technologies in which hydrogen is generated through a chemical reaction.

Common reactions involve [chemical hydrides with water or alcohols](#).

Typically, these reactions are not easily reversible on-board a vehicle.

Hence, the "spent fuel" and/or byproducts must be removed from the vehicle and regenerated off-board.

Hydrolysis Reactions

Hydrolysis reactions involve the oxidation reaction of chemical hydrides with water to produce hydrogen. The reaction of sodium borohydride has been the most studied to date.

This reaction is:



In the first embodiment, a slurry of an inert stabilizing liquid protects the hydride from contact with moisture and makes the hydride pumpable. At the point of use, the slurry is mixed with water, and the consequent reaction produces high-purity hydrogen.

The reaction can be controlled in an aqueous medium via pH and the use of a catalyst.

While the material hydrogen capacity can be high and the hydrogen release kinetics fast, the borohydride regeneration reaction must take place off-board. Regeneration energy requirements, cost, and life-cycle impacts are key issues currently being investigated. Millennium Cell has reported that their NaBH_4 -based Hydrogen on Demand™ system possesses a system gravimetric capacity of about 4 wt.%. Similar to other material approaches, issues include system volume, weight and complexity, and water availability.

Another hydrolysis reaction that is presently being investigated by Safe Hydrogen is the reaction of **MgH_2 with water to form Mg(OH)_2 and H_2** . In this case, particles of MgH_2 are contained in a non-aqueous slurry to inhibit premature water reactions when hydrogen generation is not required. Material-based capacities for the MgH_2 slurry reaction with water can be as high as 11 wt.%. However, similar to the sodium borohydride approach, water must also be carried on-board the vehicle in addition to the slurry, and the Mg(OH)_2 must be regenerated off-board.

Hydrogenation / Dehydrogenation Reactions

Hydrogenation and dehydrogenation reactions have been studied for many years as a means of hydrogen storage. For example, the decalin-to-naphthalene reaction can release 7.3 wt.% hydrogen at 210 °C via the reaction:



A platinum-based or [noble-metal-supported catalyst](#) is required to enhance the kinetics of hydrogen evolution.

[Future research](#) is directed at lowering dehydrogenation temperatures.

The advantages of such a system are that, unlike other chemical hydrogen storage concepts, the dehydrogenation does not require water.

Because the reaction is endothermic, the system would use waste heat from the fuel cell or internal combustion engine to produce hydrogen on-board.

Furthermore, liquids lend themselves to facile transport and refueling.

There are also no heat-removal requirements during refueling because regeneration would take place off-board the vehicle. Thus, the replenished liquid must be transported from the hydrogenation plant to the vehicle filling station.

Off-board regeneration efficiency and cost are important factors.

New Chemical Approaches

New chemical approaches are needed to help achieve the 2010 and 2015 hydrogen storage targets.

The concept of reacting lightweight metal hydrides such as LiH, NaH, and MgH₂ with methanol and ethanol (alcoholysis) has been put forward.

Alcoholysis reactions are said to lead to controlled and convenient hydrogen production at room temperature and below. However, as is the case with hydrolysis reactions, alcoholysis reaction products must be recycled off-board the vehicle. The alcohol must also be carried on-board the vehicle, and this impacts system-level weight, volume, and complexity.

Another new chemical approach may be hydrogen generation from ammonia-borane materials by the following reactions:

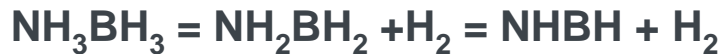

The first reaction, which occurs at less than 120 °C, releases 6.1 wt.% hydrogen while the second reaction, which occurs at approximately 160 °C, releases 6.5 wt.% hydrogen. Recent studies indicate that hydrogen-release kinetics and selectivity are improved by incorporating ammonia-borane nanosized particles in a mesoporous scaffold .

Chemical Hydrides

Hydrolysis:

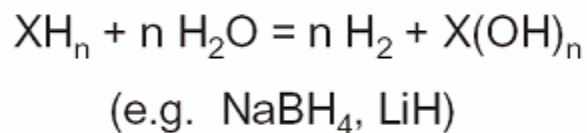

Dehydrogenation:

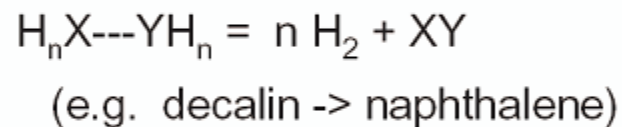

Dehydrocoupling:

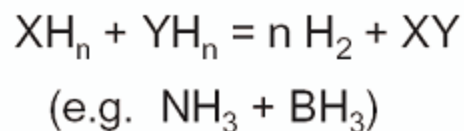

New compositions and pathways

Metal Hydrides

Metal hydrides have the potential for **reversible on-board hydrogen storage and release at low temperatures and pressures**. The optimum "operating P-T window" for PEM fuel cell vehicular applications is in the range of **1–10 atm and 25 °C–120 °C**. This is based on using the waste heat from the fuel cell to "release" the hydrogen from the media. In the near-term, waste heat less than 80 °C is available, but as high temperature membranes are developed, there is potential for waste heat at higher temperatures. A simple metal hydride such as **LaNi₅H₆**, which incorporates hydrogen into its crystal structure, can function in this range, but its gravimetric capacity is too low (~1.3 wt.%), and its cost is too high for vehicular applications.

Complex metal hydrides such as alanate (AlH₄) materials have the potential for higher gravimetric hydrogen capacities in the operational window than simple metal hydrides. Alanates can store and release hydrogen reversibly when catalyzed with titanium dopants, according to the following two-step displacive reaction for sodium alanate:



At 1 atm pressure, the first reaction becomes thermodynamically favorable at temperatures above 33°C and can release **3.7 wt.% hydrogen**, and the second reaction takes place above 110°C and can release **1.8 wt.% hydrogen**. The amount of hydrogen that a material can release, rather than only the amount the material can hold, is the key parameter used to determine system (net) gravimetric and volumetric capacities.

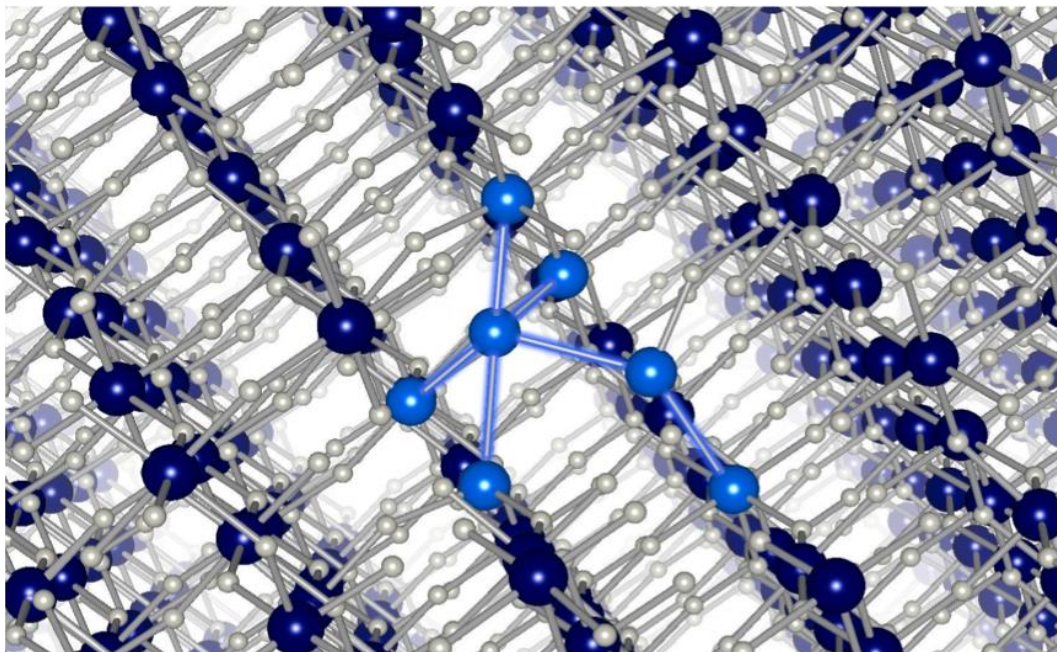

Cluster of bonded Al atoms in an Aluminum hydride (AlH₃) host crystal. The blue balls denote Al atoms and the white balls denote H atoms.

Issues with complex metal hydrides include *low hydrogen capacity, slow uptake and release kinetics, and cost*. The maximum material (not system) gravimetric capacity of 5.5 wt.% hydrogen for sodium alanate is below the 2010 DOE system target of 6 wt.%.

Thus far, 4 wt.% reversible hydrogen content has been experimentally demonstrated with alanate materials. Also, hydrogen release kinetics are too slow for vehicular applications. Furthermore, the packing density of these powders is low (for example, roughly 50%), and the system-level volumetric capacity is a challenge. Although sodium alanates will not meet the 2010 targets, it is envisioned that their continued study will lead to fundamental understanding that can be applied to the design and development of improved types of complex metal hydrides.

Recently, a new complex hydride system based on lithium amide has been developed. For this system, the following reversible displacive reaction takes place at 285°C and 1 atm:



In this reaction, 6.5 wt.% hydrogen can be reversibly stored with potential for 10 wt.%. However, the current operating temperature is outside of the vehicular operating window. However, the temperature of this reaction can be lowered to 220°C with magnesium substitution, although at higher pressures. Further research on this system may lead to additional improvements in operating conditions with improved capacity.

One of the major issues with complex metal hydride materials, due to the reaction enthalpies involved, is thermal management during refueling. Depending on the amount of hydrogen stored and refueling times required, megawatts to half a gigawatt must be handled during recharging on-board vehicular systems with metal hydrides. Reversibility of these and new materials also needs to be demonstrated for over a thousand cycles.

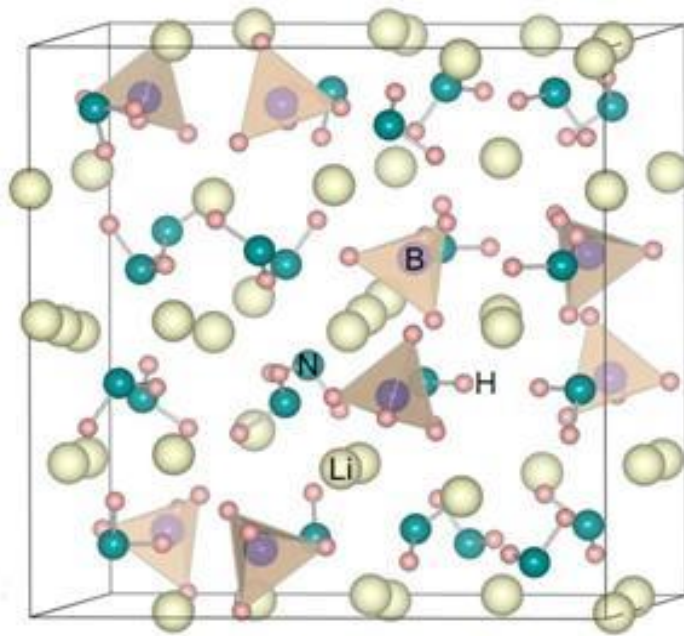

Schematic representation of $\text{Li}_4\text{BN}_3\text{H}_{10}$
- a promising material for new forms of hydrogen storage.

- **Metalni hidridi**

- neki metali apsorbiraju vodik u uvjetima visokog tlaka i umjerene temperature i tvore hidride
- najčešće se koriste slitine Mg, Ni, Fe i Ti
- kemijska veza između H_2 i metala \rightarrow više nije potreban visoki tlak
- H_2 se otpušta zagrijavanjem pri niskom tlaku
- jedan od sigurnijih načina skladištenja
- **nedostaci** :
 - a. razmjerno mali kapacitet,
 - b. veliki utjecaj nečistoća (O_2 , H_2O) koje se također mogu adsorbirati,
 - c. velike mase spremnika.

Volume Comparisons for 4 kg Vehicular H₂ Storage

Figure 1 Volume of 4 kg of hydrogen compacted in different ways, with size relative to the size of a car. (Image of car courtesy of Toyota press information, 33rd Tokyo Motor Show, 1999.)



Schlapbach & Züttel, Nature, 15 Nov. 2001

Desired binding energy range

Potential energy for molecular and atomic hydrogen absorption

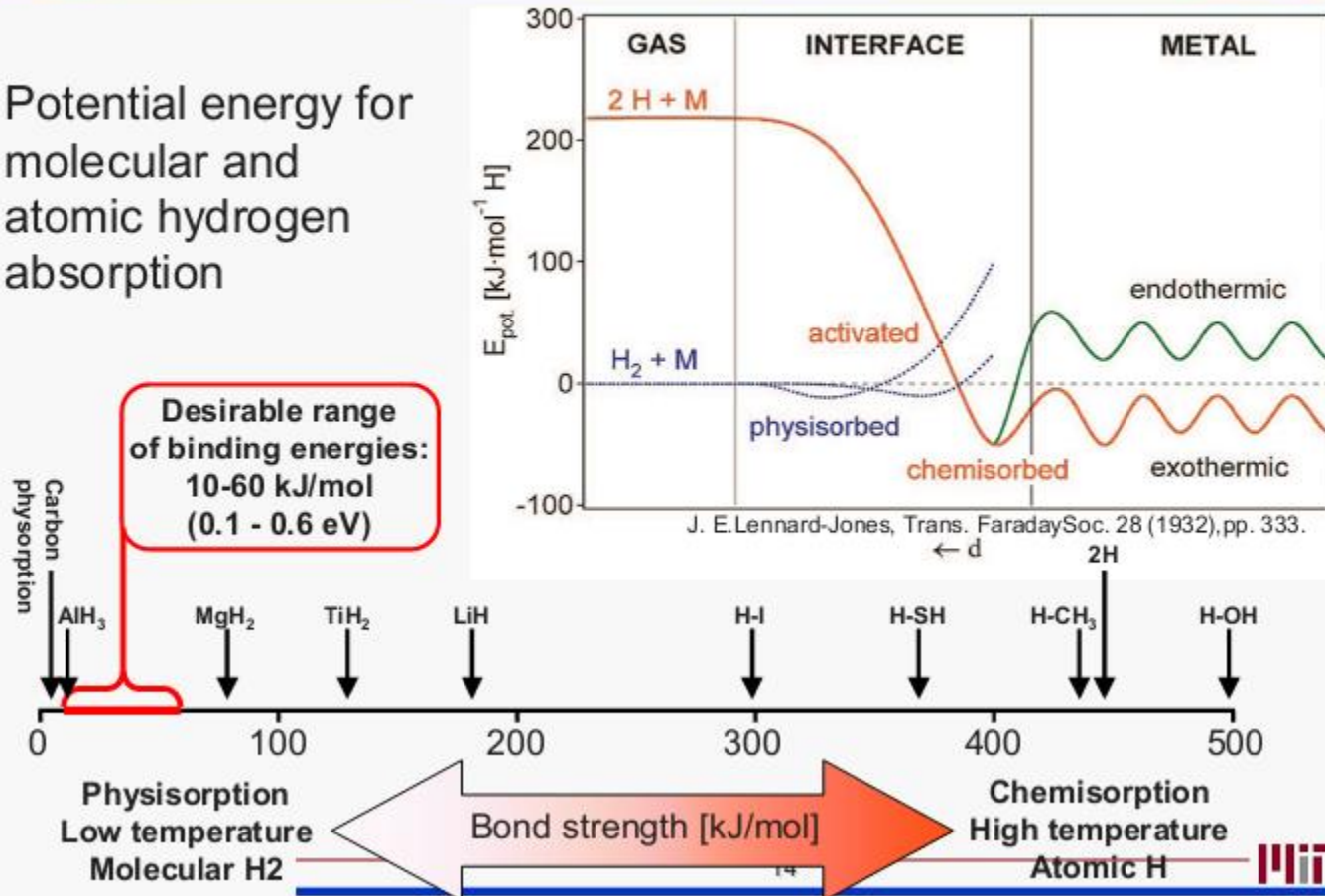

Chemisorption

HYDRIDES

	Material	H ₂ [mass%]	T _{dec} [°C] 1 bar
	LaNi ₅ H ₆	1.49	15
Metal hydrides	TiMn _{1.5} H _{2.5}	1.76	
	FeTiH ₂	1.86	-10
	ZrH ₂	2.16	
MgH ₂ , AlH ₃	TiCr _{1.8} H _{3.5}	2.43	
	Mg ₂ NiH ₄	3.62	300
	VH ₂	3.81	-10,
XAlH ₄ , XBH ₄	TiH ₂	3.98	780
	NaH	4.20	430
	CaH ₂	4.79	1000
-NH ₂ , =NH	Li ₂ NH + LiH	5.50	600
	LiNH ₂ + LiH	6.50	300
H ^{δ+} and H ^{δ-}	NaAlH ₄	7.46	30, 120
	MgH ₂	7.66	320
	AlH ₃	10.07	<RT
	LiAlH ₄	10.62	-93
	NaBH ₄	10.66	620
	LiH	12.86	900
	Al(BH ₄) ₃	16.90	<100
	NH ₃	17.75	-32
	LiBH ₄	18.51	230

- Metal hydrides: MgH_2
- Complex hydrides: NaAlH_4
- Chemical hydrides: LiBH_4 , NH_3BH_3

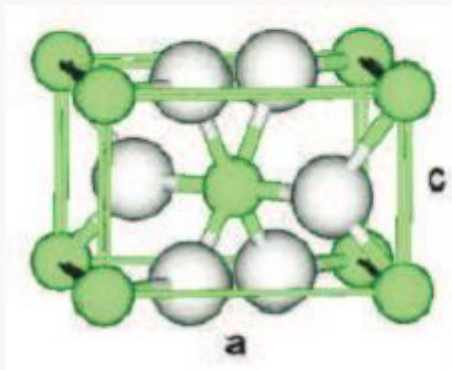

MgH_2

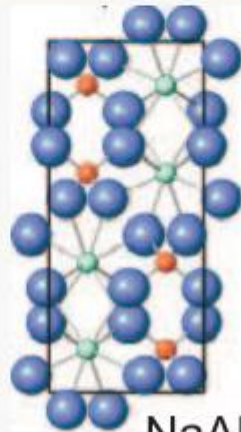

NaAlH_4

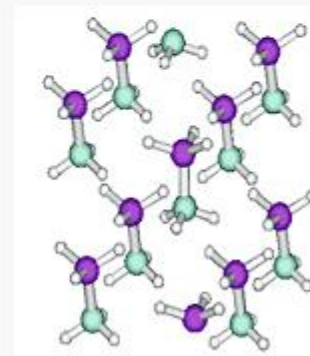

NH_3BH_3

The Hydrogen Bottleneck

	DOE goal (2015)	Metal hydride	Chemical hydride
Storage wt. %	9%	✓	✓
Storage vol. %	81 kg/m ³	✓	✓
Reversibility (cycle)	1500 cycles	Limited	✗
System storage cost	\$2/kWh	\$50/kWh	\$18/kWh
Fueling time (reaction kinetics)	30 s/kg-H ₂	✗ (too slow)	✗
Operating temperature	-40 - 60 °C	✗ (too high)	✓
Operating pressure	<100 atm.	✓	✓

Mehanizam apsorpcije atoma vodika u metalnu rešetku

- Molekule vodika primaju se na površinu metala gdje se zatim molekula disocira te se atomi vodika pojedinačno infiltriraju u metalnu rešetku
- Atomi vodika su vrlo lagani i puno manjih dimenzija od atoma metala te stoga vrlo brzo difundiraju s površine u metalnu rešetku
- Novonastala veza je vrlo jaka te je potrebna uložiti energiju da bi se atom vodika izbacio iz rešetke

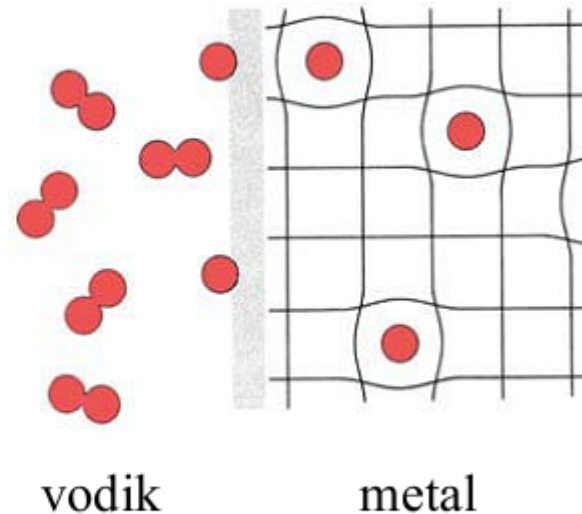

PCT krivulja

- PCT krivulja (pressure-composition-temperature) je osnovna karakteristika svakog hidrida. Ona se izrađuje mjerenjem promjene tlaka pri konstantnoj temperaturi prilikom apsorpcije vodika u metalnu rešetku. Hidracija rešetki intermetalnih spojeva uzrokuje povećanje volumena što može dovesti do loma rešetki. Ovaj lom uzrokuje povećanje aktivne površine što vodi povećanoj reaktivnosti vodika.
- Većina metala jako privlači vodik dok ih nekoliko ima vrlo slabu privlačnost te reakcija stoga može biti egzotermna odnosno endotermna. Proces apsorpcije odnosno desorpcije se najbolje vidi na PCT krivulji

PCT krivulja

- Na apscici dijagrama PCT krivulje prikazan je maseni omjer vodika i metala dok je na ordinati prikazan tlak u logaritamskom mjerilu.
- Tlak u početku naglo skače s porastom mase vodika, zatim u središnjem dijelu gradijent porasta tlaka naglo pada da bi pri kraju ponovno naglo skočio
- Središnji dio u kojem se udio vodika značajno mijenja s malom promjenom tlaka zove se ravnotežni tlak

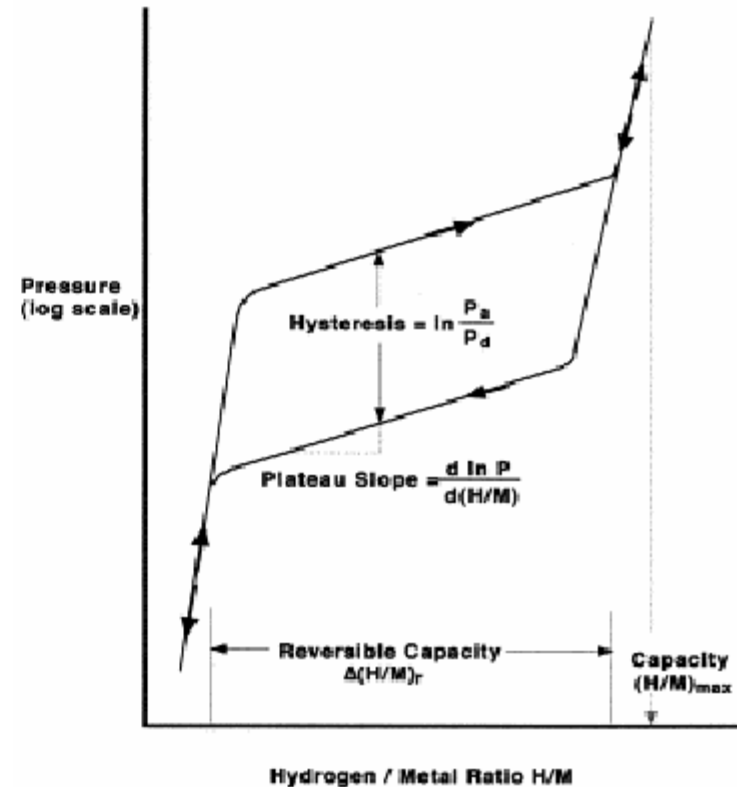

Plateauov nagib i histereza

- Duljina linije ravnotežnog tlaka odgovara reverzibilnom kapacitetu a nagib krivulje u tom području naziva se Plateauov nagib

$$\text{Plateauov nagib} = d(\ln p)/d(H/M)$$

- Ravnotežni tlak apsorpcije vodika nešto je veći od tlaka desorpcije vodika i ta razlika u tlakovima se naziva histerezom.

$$\text{Histereza} = \ln(p_a/p_d)$$

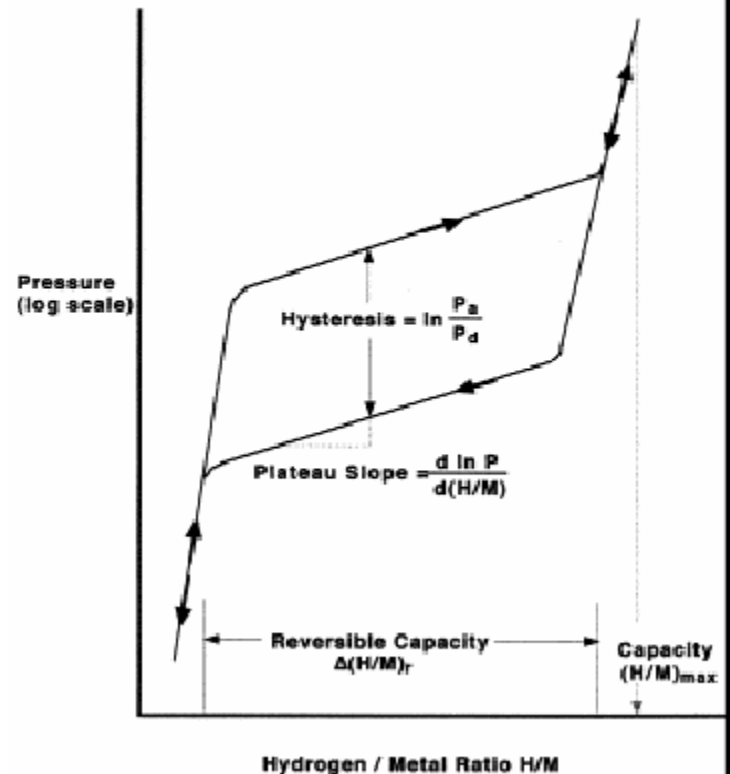

Toplina reakcije

- Većina hidrida pri apsorpciji vodika otpušta toplinu u okolinu i obrnuto, pri desorpciji uzima toplinu od okoline



- Ideja je da se toplina ili entalpija reakcije, ΔH , u mobilnim aplikacijama uzima iz otpadne topline pogonskih uređaja. Stoga je poželjna temperatura desorpcije $< 100^\circ\text{C}$ da bi bilo kompatibilno sa radnom temperaturom npr. PEM gorivnih članaka te s što manji ΔH
- Manji ΔH znači veći radni tlak za konst. T

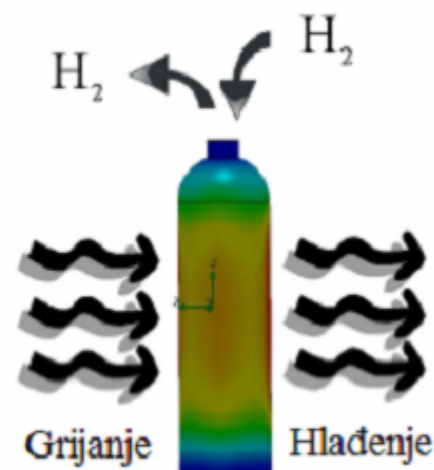

- Filter of proper pore size and area must be used. ($10\ \mu$, $5\ \text{cm}^2/\text{kg H}_2$)

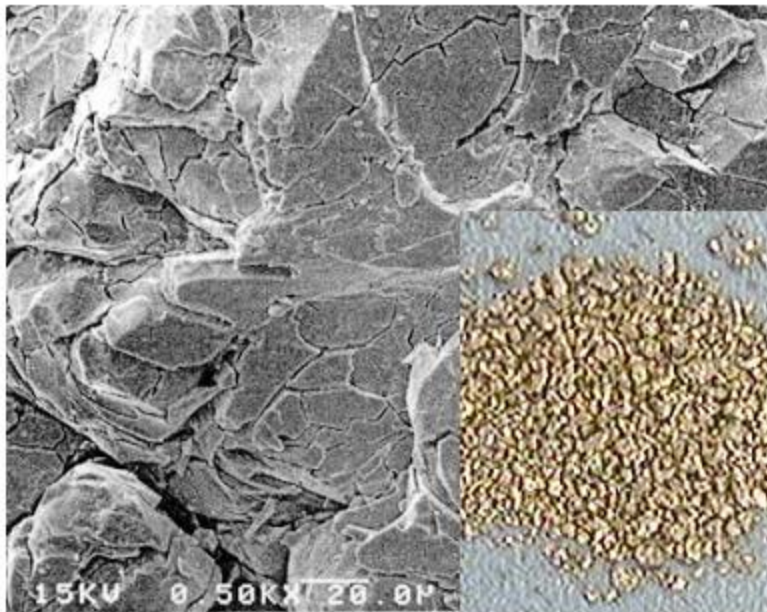

mm size particle after
1 absorption



After 10 absorptions
particles size ~ 10 micron

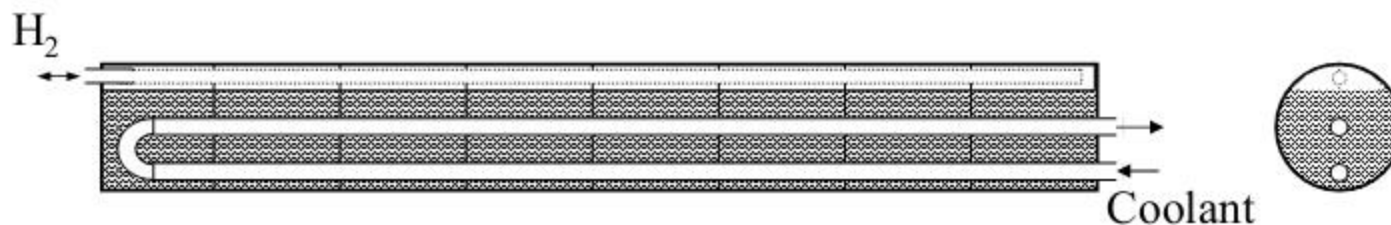

Metal hydride powder

US patent 6,015,041
EP 0 891 294 B1

Metal hydride canisters allow safe and reliable storage of hydrogen for you fuel cells or chromatographs. Hydrogen is stores at low pressure and ambient temperature in compact canisters for easy transportation.

Hydrogen is stored when absorbed by the chemical “sponge” formed by specific metallic powders. Hydrogen is released at controlled pressure and flow at room temperature.



Technical Specifications:

Dimensions:	Ø47 x L360 mm
Weight:	App. 3 kg
Storage capacity:	300 NL (standard liter)
Vessel material:	Stainless steel
Connector:	Swagelok Quick Coupling 4 series, brass
Discharge pressure:	0.3M Pa (20 °C)
Flow rate:	2-3 NL/min (RT to 25 °C, air convection) 5 NL/min (20 °C water bath)
Recharge time:	≤30 min; 20 °C water bath

7 875,00 € tax excl.

Hydrogen Storage in Hydrides

Nanostructured hydrides by ball milling/alloying

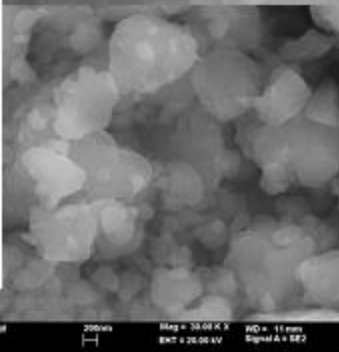

File Name = TMEK1-25-206.tif | 200kx | Mag = 30.0k X | HD = 11 mm | EXT = 25.00 kV | Signal A = SE2

Nanocatalysts

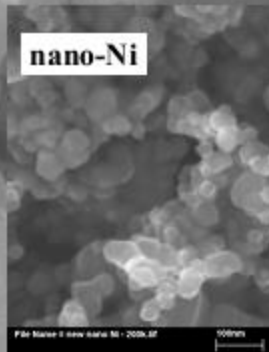

File Name = 2 new nano Ni - 2006.tif | 100kx | Mag = 200.0k X | HD = 4 mm | EXT = 25.00 kV | Signal A = SE2

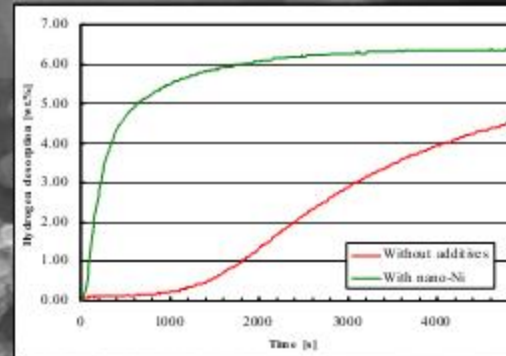

Specific Opportunity - Hydride Tank

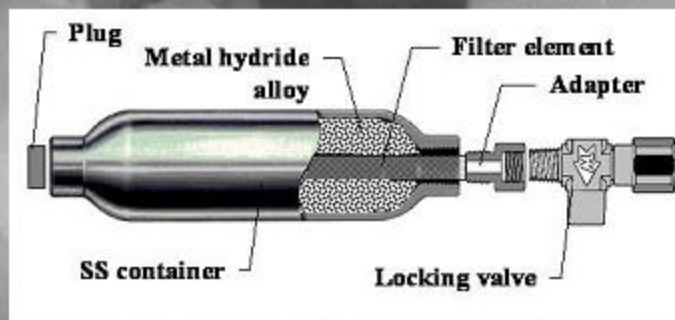

Metal Hydride H₂ Fuel Cell Power System

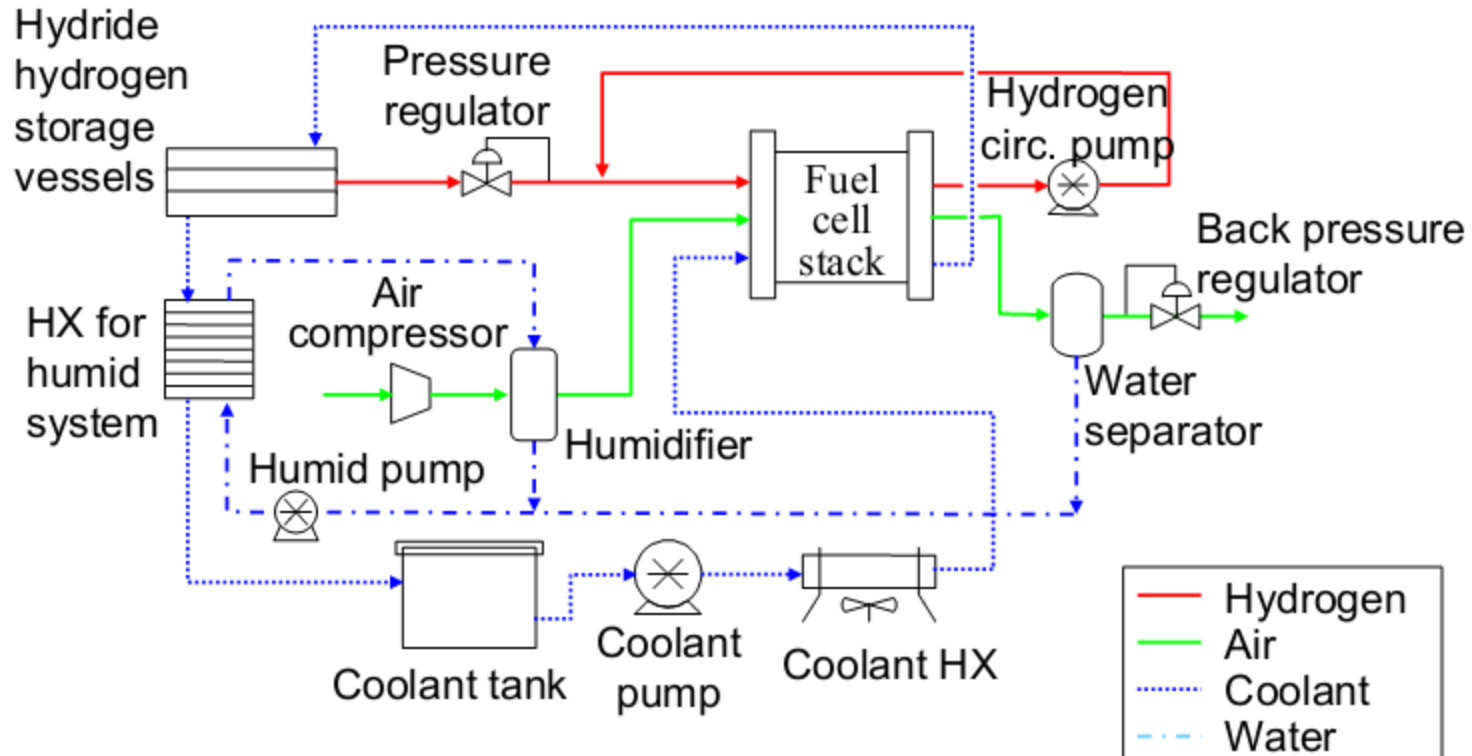

Figure 2. The power system of Gator 2.

Summery

- Present hydrogen storage methods are feasible but not practical for a hydrogen economy
- Metal hydrides though heavy do have advantages and may find niche applications
- Lighter metal hydrides (solid absorbents) are needed
- SRTC metal hydride vessel technology is applicable to both stationary and mobile applications
- Hydrogen economy requires a better storage method that is to be discovered.